

OPERATION MANUAL



WOOD BAND SAW

Models

BP-430A BP-480A

Order Code W4330, Order Code W4340

Edition No : BP-430A,480A-1

Date of Issue : 11/2020

MACHINE DETAILS**MACHINE**

WOOD BAND SAW

MODEL NO.**SERIAL NO.****DATE OF MANF.**

DISTRIBUTED BY

www.machineryhouse.com.auWWW.MACHINERYHOUSE.CO.NZ**NOTE:**

This manual is only for your reference. Owing to the continuous improvement of the HAFCO machines, changes may be made at any time without obligation or notice. Please ensure the local voltage is the same as listed on the specification plate before operating this electric machine.

**NOTE:**

In order to see the type and model of the machine, please see the specification plate. Usually found on the back of the machine. See example (Fig.1)

A rectangular product specification plate with the HAFCO logo at the top. Below the logo, it says "PRODUCT SPECIFICATION". There are seven rows, each with a label and a corresponding empty rectangular box for input: MODEL:, CAPACITY:, SER. NO:, MFG DATE:, WEIGHT:, VOLTS:, and MOTOR Kw:. At the bottom, it includes the website www.machineryhouse.com.au and "Made in China".

HAFCO	
PRODUCT SPECIFICATION	
MODEL:	<input type="text"/>
CAPACITY:	<input type="text"/>
SER. NO:	<input type="text"/>
MFG DATE:	<input type="text"/>
WEIGHT:	<input type="text"/>
VOLTS:	<input type="text"/>
MOTOR Kw:	<input type="text"/>
www.machineryhouse.com.au Made in China	

FIG.1

CONTENTS:

1. GENERAL MACHINE INFORMATION	
1.1 Specifications.....	4
1.2 Identification.....	5
2. SAFETY	
2.1 General Wood Working Machine Safety.....	6
2.2 Specific Safety For Drill/Mill.....	9
3. POWER SUPPLY	
3.1 Electrical Installation.....	9
3.2 Full Load Current.....	9
4. SETUP	
4.1 Unpacking.....	11
4.2 Clean Up.....	11
4.3 Site Preparation.....	11
4.4 Lifting Instructions.....	11
4.5 Anchoring To The Floor.....	12
4.6 Machine Leveling.....	12
4.7 Assembly.....	13
4.8 Tensioning The Blade.....	15
4.9 Blade Tracking.....	16
4.10 Table Stop Calibration.....	17
4.11 Test Run.....	17
5. OPERATION	
5.1 Operation Overview.....	18
5.2 Blade Information.....	19
5.3 Changing The Blade.....	20
5.4 Adjusting The Speed.....	20
5.5 Tilting The Table.....	21
5.6 Adjusting Support Bearings.....	22
5.7 Blade Guide Adjustments.....	22
6. MAINTENANCE	
6.1 Troubleshooting.....	23
6.2 Wheel Alignment.....	24
Spare Parts.....	25
Risk Assessment Sheets.....	47

1.1 SPECIFICATION

Order Code	W4330	W4340
MODEL	BP-430A	BP-480A
Wheel Diameter (Ø) (mm)	430	480
Throat Capacity (mm)	410	462
Height Capacity (mm)	300	300
Max. Cutting with Rip Fence (mm)	370	422
Table Size (mm)	585 x 435	680 x 480
Table Tilt Left (deg)	10	10
Table Tilt Right (deg)	45	45
Saw Blade Speed (m/m)	488 / 1010	488 / 1010
Motor Power (kW / hp)	1.5 / 2	1.5 / 2
Voltage / Amperage (V / amp)	240 / 10	240 / 10
Blade Code (Suits)	W433A, W433B, W433C	W434A, W434B
Blade Size (L x W x T) (mm)	3340 x 12 x 0.80	3630 x 19 x 0.80
Blade Width Range (mm)	6 - 25	6 - 25
Dust Chute Diameter (Ø) (mm)	100	100
Floor Space (W x D x H) (mm)	850 x 830 x 1860	915 x 762 x 1980
Shipping Dimensions (L x W x H) (mm)	762 x 508 x 2000	864 x 508 x 2160
Nett Weight (kg)	156	185

1.3 IDENTIFICATION

Become familiar with the names and locations of the controls and features shown below to better understand the instructions in this manual.

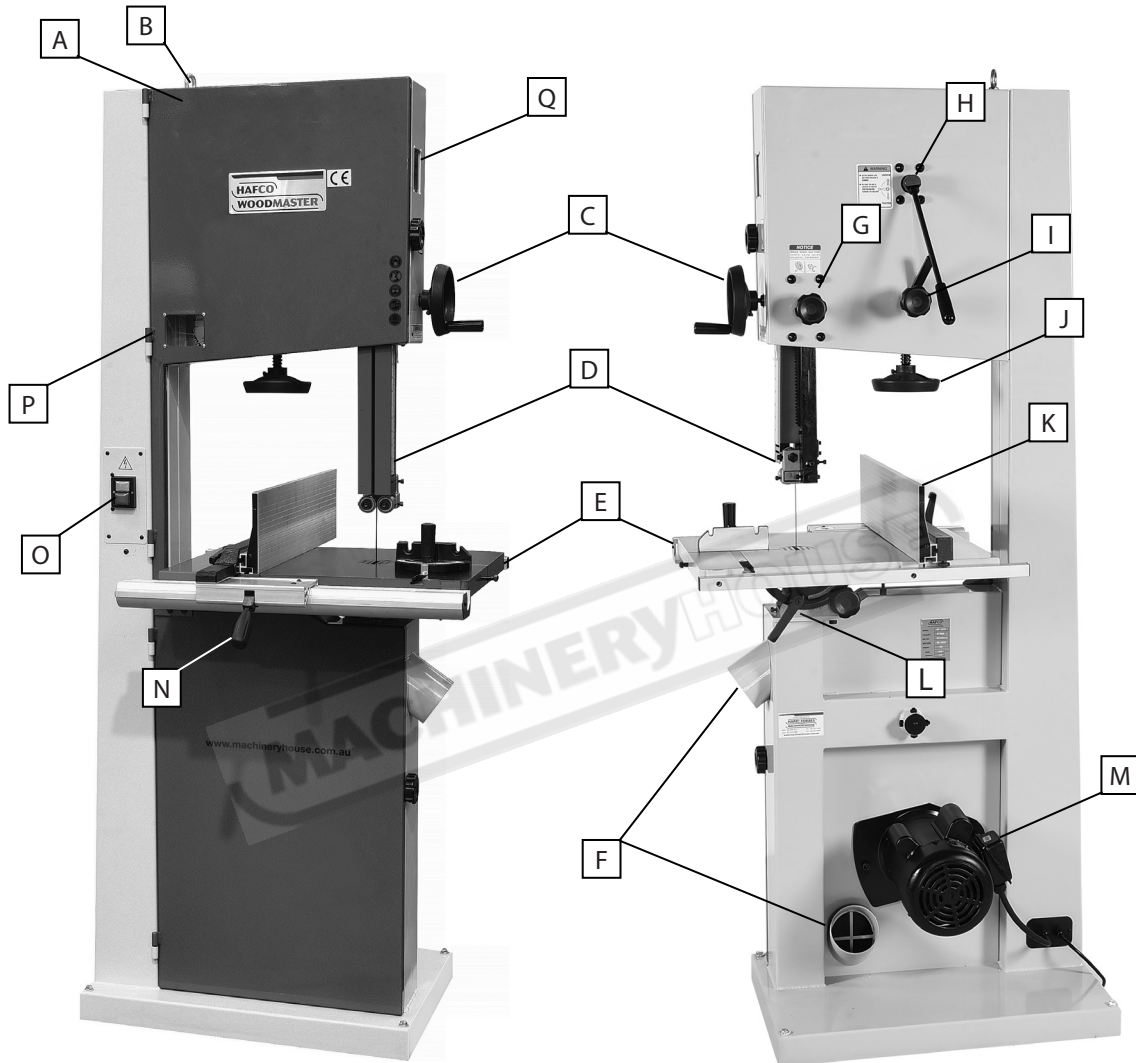

A	Upper Wheel Cover	I	Top Wheel Adjuster
B	Lifting Point	J	Blade Tension Adjuster
C	Guide Post Hand Wheel	K	Fence
D	Upper Ball Bearing Guide	L	Table Tilt Adjuster
E	Table	M	Motor
F	Dust Ports	N	Fence Position Lock
G	Upper Bearing Support Lock	O	ON/OFF Buttons
H	Quick Change Blade Lever	P	Blade Tension Window
		Q	Tracking Window

2.1 GENERAL WOODWORKING MACHINE SAFE PRACTICES

DO NOT use this machine unless you have read this manual and have been instructed in the use of this machine in its safe use and operation



WARNING

This manual provides safety instructions on the proper setup, operation, maintenance, and service of this machine. Save this manual, refer to it often, and use it to instruct other operators. Failure to read, understand and follow the instructions in this manual may result in fire or serious personal injury—including amputation, electrocution, or death.

The owner of this machine is solely responsible for its safe use. This responsibility includes, but is not limited to proper installation in a safe environment, personnel training and authorization to use, proper inspection and maintenance, manual availability and comprehension, of the application of the safety devices, integrity, and the use of personal protective equipment.

The manufacturer will not be held liable for injury or property damage from negligence, improper training, machine modifications or misuse.



Exposure to the dust created by power sanding, sawing, grinding, drilling and other construction activities may cause serious and permanent respiratory or other injury, including silicosis (a serious lung disease), cancer, and death. Avoid breathing the dust, and avoid prolonged contact with dust. Some examples of these chemicals are:



- Lead from lead-based paints.
- Crystalline silica from bricks, cement and other masonry products.
- Arsenic and chromium from chemically-treated timber.

Always operate tool in well ventilated area and provide for proper dust removal. Use a dust collection system along with an air filtration system whenever possible. Always use properly fitting approved respiratory protection appropriate for the dust exposure, and wash exposed areas with soap and water.

- ✓ Always wear safety glasses or goggles and protective footwear.
- ✓ Wear dust masks when required.
- ✓ Wear hearing protection that is suitable for the level and frequency of the noise you are exposed to in the woodworking area. If you have trouble hearing someone speak from three feet away, the noise level from the machine may be hazardous.
- ✓ Use gloves to protect hands from splinters when handling wood but do not wear them near rotating blades and other machinery parts where the gloves can catch.

2.1 GENERAL WOODWORKING MACHINE SAFE PRACTICES

- ✓ Make sure the guard that is in position is in good working condition, and guards the machine adequately before operating any equipment or machine. Check and adjust all other safety devices.
- ✓ Make sure the equipment is properly grounded before use.
- ✓ Check that keys and adjusting wrenches are removed from the machine before turning on the power.
- ✓ Inspect stock for nails or other materials before cutting, planing, routing or carrying out similar activities.
- ✓ Make sure that all machines have start and stop buttons within easy and convenient reach of an operator. Start buttons should be protected so that accidental contact will not start machine.
- ✓ Ensure that all cutting tools and blades are clean, sharp, and in good working order so that they will cut freely, not forced.
- ✓ Turn the power off and unplug the power cord (or lock out the power source) before inspecting, changing, cleaning, adjusting or repairing a blade or a machine. Also turn the power off when discussing the work.
- ✓ Use a "push stick" to push material into the cutting area. Jigs are also useful in keeping hands safe during cutting procedures. Keep hands out of the line of the cutting blade.
- ✓ Always use a push stick for pieces less than 30 cm in length, or for the last 30 cm of a longer cut. Use a push stick to remove the cut piece from between the fence and the blade.
- ✓ Clamp down and secure all work pieces when drilling or milling.
- ✓ Use good lighting so that the work piece, cutting blades, and machine controls can be seen clearly. Position or shade lighting sources so that they do not shine in the operator's eyes or cause any glare and reflections.
- ✓ Ensure that the floor space around the equipment is sufficient to enable you to machine the size of work piece being processed safely without bumping into other workers or equipment.
- ✓ Woodworking machines should be fitted with efficient and well-maintained local exhaust ventilation systems to remove sawdust or chips that are produced.
- ✓ Electric power cords should be above head level or in the floor in such a way that they are not tripping hazards.
- ✓ Keep work area free of clutter, clean, well swept, and well lit. Spills should be cleaned up immediately. Floor areas should be level and non-slip. Good housekeeping practices and workplace design will reduce the number of injuries and accidents from slips, trips, and falls.
- ✓ Do not wear loose clothing, work gloves, neckties, rings, bracelets or other jewelry that can become entangled with moving parts. Confine long hair.
- ✓ Avoid awkward operations and hand positions where a sudden slip could cause your hand to move into the cutting tool or blade.
- ✓ Do not remove sawdust or cuttings from the cutting head by hand while a machine is running. Use a stick or brush when the machine has stopped moving.
- ✓ Do not use compressed air to remove sawdust, turnings, etc. from machines or clothing.
- ✓ Do not leave machines running unattended (unless they are designed and intended to be operated while unattended). Do not leave a machine until the power off is turned off and the machine comes to a complete stop.

2.1 GENERAL WOODWORKING MACHINE SAFE PRACTICES.

- ✓ Do not try to free a stalled blade before turning the power off.
- ✓ Do not distract or startle an operator while he or she is using woodworking equipment.
- ✓ Horseplay should be prohibited. It can lead to injuries.

HAZARDS ASSOCIATED WITH MACHINES INCLUDE, BUT ARE NOT LIMITED TO:

- Being struck by ejected parts of the machinery
- Being struck by material ejected from the machinery
- Contact or entanglement with the machinery
- Contact or entanglement with any material in motion

HEALTH HAZARDS (other than physical injury caused by moving parts)

- Chemicals hazards that can irritate, burn, or pass through the skin
- Airborne substances that can be inhaled, such as oil mist, metal fumes, solvents, and dust
- Heat, noise, and vibration
- Ionizing or non-ionizing radiation (X-ray, lasers, etc.)
- Biological contamination and waste
- Soft tissue injuries (for example, to the hands, arms, shoulders, back, or neck) resulting from repetitive motion, awkward posture, extended lifting, and pressure grip)

OTHER HAZARDS

- Slips and falls from and around machinery during maintenance
- Unstable equipment that is not secured against falling over
- Safe access to/from machines (access, egress)
- Fire or explosion
- Pressure injection injuries from the release of fluids and gases under high pressure
- Electrical Hazards, such as electrocution from faulty or ungrounded electrical components
- Environment in which the machine is used (in a machine shop, or in a work site)



Machines are safeguarded to protect the operator from injury or death with the placement of guards. Machines must not be operated with the guards removed or damaged.

2.2 SAFE WORK PROCEDURE FOR BAND SAWS

DO NOT use this machine unless you have been instructed in its safe use and operation and have read and understood this manual



Safety glasses must be worn at all times in work areas



Long and loose hair must be contained.



Gloves must not be worn when using this machine.



Sturdy footwear must be worn at all times in work areas



Close fitting protective clothing must be worn



Rings and jewellery must not be worn.

PRE-OPERATIONAL SAFETY CHECKS

1. Ensure no slip/trip hazards are present in workspaces and walkways.
2. Locate and ensure you are familiar with the operation of the ON/OFF starter and E-Stop.
3. Check that all guards are in position.
4. Ensure push stick is available.
5. Lower the blade guide and guard to full effect.
6. Start the dust extraction unit before using the saw.
7. Faulty equipment must not be used. Immediately report suspect machinery.

OPERATIONAL SAFETY CHECKS

NOTE : Keep your fingers off the line of the cut at all times.

1. Never leave the machine running unattended.
2. The work piece should be fed forward evenly and held firmly on the table to ensure effective control during cutting whilst keeping hands in a safe position.
3. Use a push stick when feeding material past the blade.
4. Do not force a wide blade on a cut of small radius. Use relief cuts when cutting sharp curves.
5. Before making adjustments switch off the saw and bring the machine to a complete stand still.
6. Stop the machine before attempting to back the work away from the blade.
7. Stop the saw immediately if the blade develops a 'click'. Report it to your supervisor

AFTER OPERATION

1. Switch off the saw and reset all guards to a fully closed position.
2. Leave the machine in a safe, clean and tidy state.

DO NOT

- Attempt to cut very small item
- Cut cylindrical or irregular stock
- Leave the machine running unattended

3. POWER SUPPLY

3.1 ELECTRICAL INSTALLATION

Place the machine near an existing power source. Make sure all power cords are protected from traffic, material handling, moisture, chemicals, or other hazards. Make sure there is access to a means of disconnecting the power source. The electrical circuit must meet the requirements for 240V.

NOTE: *The use of an extension cord is not recommended as it may decrease the life of electrical components on your machine.*

ELECTRICAL REQUIREMENTS	BP-430A	BP-480A
Nominal Voltage.....	240V	240V
Cycle.....	50 Hz	50Hz
Phase.....	Single Phase	
Power Supply Circuit.....	10 Amps	10 Amps
Full Load Current.....	5 Amps	5 Amps

(Full load current rating is also on the specification plate on the motor.)

3.2 FULL-LOAD CURRENT RATING

The full-load current rating is the amperage a machine draws when running at 100% of the output power. Where machines have more than one motor, the full load current is the amperage drawn by the largest motor or a total of all the motors and electrical devices that might operate at one time during normal operations.

Full-Load Current Rating for these machine at 240V is 5 Amps

It should be noted that the full-load current is not the maximum amount of amps that the machine will draw. If the machine is overloaded, it will draw additional amps beyond the full-load rating and if the machine is overloaded for a long period of time, damage, overheating, or fire may be caused to the motor and circuitry.

This is especially true if connected to an undersized circuit or a long extension lead. To reduce the risk of these hazards, avoid overloading the machine during operation and make sure it is connected to a power supply circuit that meets the requirements.



4 SETUP

4.1 UNPACKING

This machine was carefully packaged for safe transport. When unpacking, separate all enclosed items from packaging materials and inspect them for shipping damage. If items are damaged, please contact your distributor.

NOTE: Save all the packaging materials until you are completely satisfied with the machine and have resolved any issues with the distributor, or the shipping agent.

When unpacking, check the packing list to make sure that all parts shown are included. If any parts are missing or broken, please contact the your distributor.

4.2 CLEAN - UP

The unpainted surfaces of the machine have been coated with a waxy oil to protect them from corrosion during shipment. Remove the protective coating with a solvent cleaner or a citrus based degreaser.

Optimum performance from your machine will be achieved when you clean all moving parts or sliding contact surfaces that are coated with rust prevented products.

It is advised to avoid chlorine based solvents, such as acetone or brake parts cleaner, as they will damage painted surfaces and strip metal should they come in contact. Always follow the manufacturer's instructions when using any type of cleaning product.

4.3 SITE PREPARATION

When selecting the site for the machine, consider the largest size of workpiece that will be processed through the machine and provide enough space around the machine for operating the machine safely. Consideration should be given to the installation of auxiliary equipment. Leave enough space around the machine to open or remove doors/covers as required for the maintenance and service as described in this manual.

It is recommended that the machine is anchored to the floor to prevent tipping or shifting. It also reduces vibration that may occur during operation.

4.4 LIFTING INSTRUCTIONS



WARNING

This machine is extremely heavy.

Serious personal injury may occur if safe moving methods are not followed. To be safe, you will need assistance and power equipment when moving the shipping crate and removing the machine from the crate.



On the day that the machine arrives, make sure that a forklift or lifting device, with sufficient capacity is available to unload the machine from the vehicle. Ensure access to the chosen site is clear and that doors and ceilings are sufficiently high and wide enough to receive the machine.

4.4 LIFTING INSTRUCTIONS CONT.

LIFTING POINT

An eye bolt lifting point has been provided on the top of the machine. (Fig.4.1)

When lifting the machine only certified lifting slings should be used.

Ensure that when lifting, the machine does not tip over. Check that the lifting slings do not interfere with the parts of the machine that may be damaged.

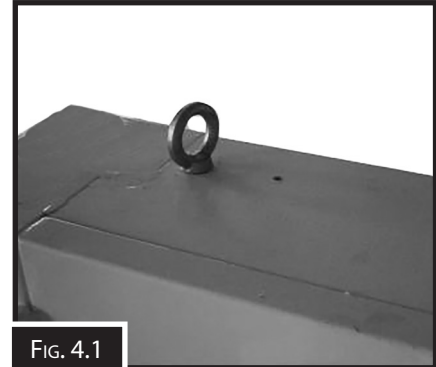

FIG. 4.1

4.5 ANCHORING TO THE FLOOR

OPTIONS FOR MOUNTING

The machine is best mounted on a concrete slab.

Masonry anchors with bolts are the best way to anchor machinery, because the anchors sit flush with the floor surface, making it easy to unbolt and move the machine later, if needed. (Fig. 4.2)

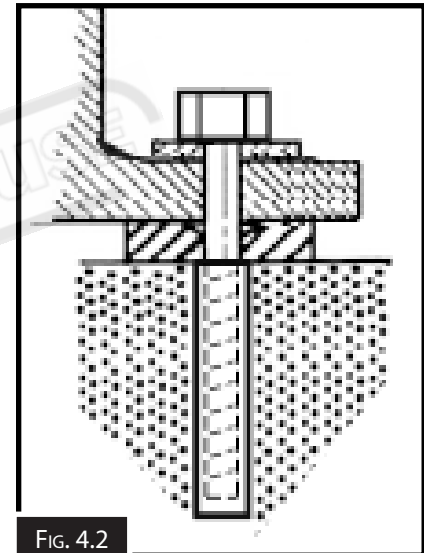

FIG. 4.2

4.6 MACHINE LEVELLING

To set your machine up so that it operates to optimum performance, apply the following procedure

After your machine has been anchored to a concrete slab floor, it then needs to be leveled. Loosen the hold down bolts and place a level on the surface of the working table. Metal shims need to be placed under corner of the base of the machine until level. Once level then tighten the hold down bolts. (Fig. 4.3).

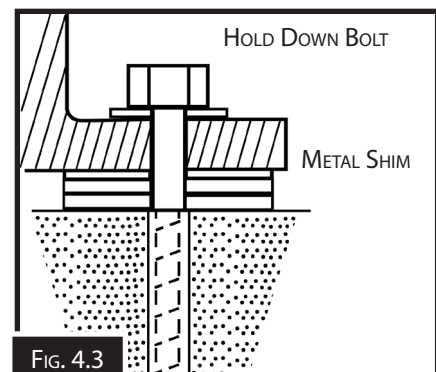

FIG. 4.3

NOTE: The machine must not rest on supports other than those defined in Fig. 4.3

4.7 ASSEMBLY

The machine must be fully assembled before it can be operated. First clean any parts that are coated in rust preventative to ensure the assembly process can proceed smoothly.

INSTALLING THE GUIDE POST HAND WHEEL

1. Attach the guide post hand wheel onto the shaft making sure that the grub screw will locate on the flat on the shaft. (Fig. 4.4)

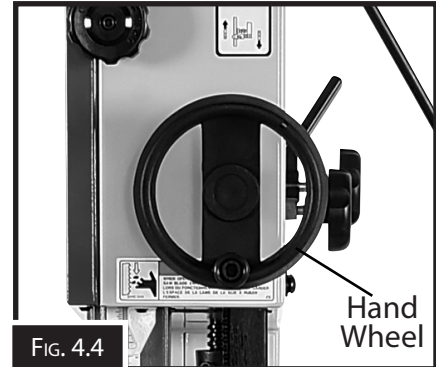

INSTALLING THE TABLE

The table is heavy and will require the assistance of another person. To make the installation easier, first remove the saw blade

To install the table

1. Release the blade tension on the saw blade move the blade tension lever to the left. (Fig. 4.5)
2. Adjust the upper and lower blade guides so that the blade is free to move.
3. Once the blade is removed with the help of another person, lift the table on to the trunnion support bracket and secure it with the four M8 x 16mm bolts, and M8 flat and spring washers. (Fig. 4.6)
4. Remove the table insert and the table pin and slide the blade through the table slot, making sure that the teeth are facing down. (Fig. 4.7)
5. Place the blade between the upper and lower guides and place the blade over the upper and lower wheels.
6. Tighten the quick release tension lever, then install the table insert and table pin.
7. Don't adjust the upper and lower blade guides until the the blade tracking and tension have been adjusted.

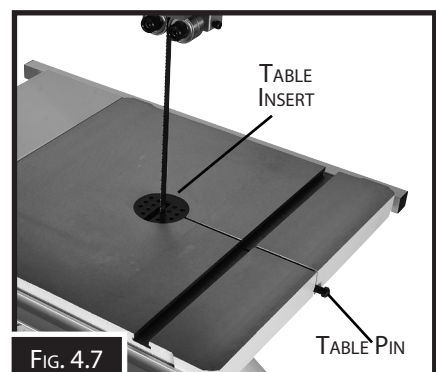
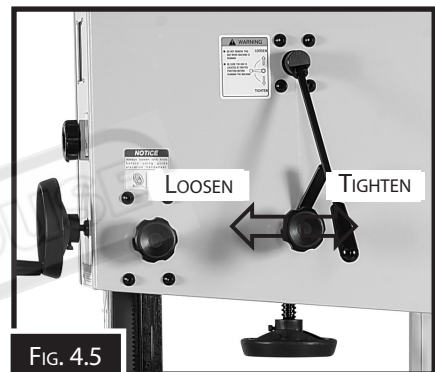

INSTALLING THE FENCE

1. Attach the back support square tube to the back of the table with the two M6 x 16 socket head cap screws, making sure that the rail is parallel to the table. (Fig. 4.8)
2. Attach the front rail to the table with the two M6 x 20 hex head bolts, 6mm lock washers, and 6mm flat washers. (Fig. 4.9)
3. Install an M8 hex nut on the fence handle, then thread the handle into the fence assembly, and tighten the hex nut against the fence pivot block to secure the handle. (Fig. 4.10)
4. Adjust the rail pad screw on the back end of the fence to and check that the fence locks at both ends. (Fig. 4.11)

NOTE: *The fence upright can be fitted in the low or in the high position depending on the workpiece being worked.*

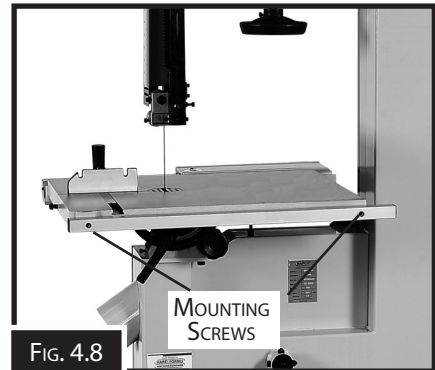

FIG. 4.8

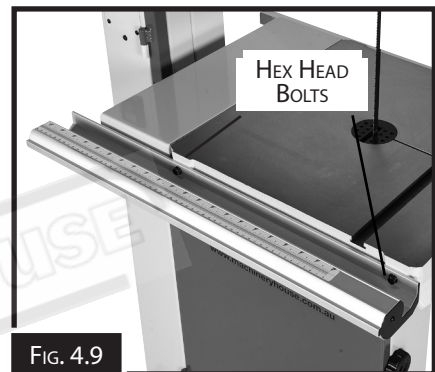

FIG. 4.9

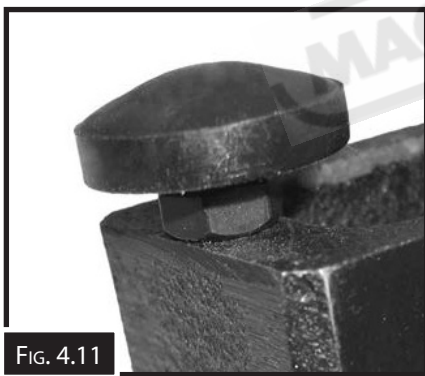

FIG. 4.11



FIG. 4.10

CONNECTING THE DUST HOSE:

Fit the 4" dust hose over the dust port and secure it in place with a hose clamp making sure it will not come off. (Fig 4.12)

⚠ WARNING *These band saws create substantial amounts of wood dust when operating, and should not be used without an adequate dust collection system. Failure to use a dust collector may result in short and longterm respiratory illness.*



FIG. 4.12

4.8 TENSIONING THE BLADE.

A properly tensioned blade is essential for making accurate cuts and is necessary before making other band saw adjustments. (For blade change instructions see Page 20)

To tension the blade:

1. DISCONNECT THE MACHINE FROM THE POWER SUPPLY
2. Raise the upper blade guide assembly as high as it will go, (Fig.4.13) and adjust the upper and lower guide blocks approximately 0.5mm away from the blade. (Fig. 4.14)
3. Ensure the blade tension quick-release lever is in the tighten position
4. Adjust the blade tension hand wheel. Turning the tension hand wheel clockwise will increase the blade tension and tuning the tension hand wheel counter-clockwise reduces the blade tension.

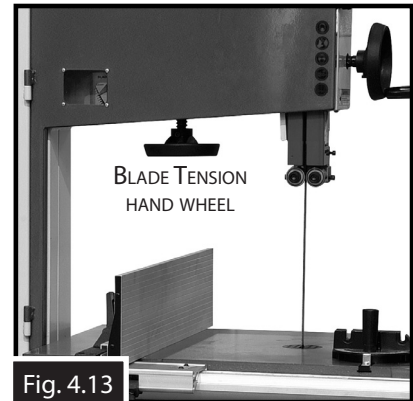

Fig. 4.13

NOTE: This procedure will not work if the guide blocks have any contact with the blade.

5. Check the tension by pushing with a finger against the side of the blade, halfway between table and upper guide, (the blade should flex approximately 6mm)
6. Turn the band saw ON, and very slowly release the tension one quarter of a turn at a time. When you see the band saw blade start to flutter, stop decreasing the tension.
7. Now, slowly increase the tension until the blade stops fluttering, then tighten the tension another quarter of a turn.
8. Note what the tension gauge reads. Use that as a guide for tensioning that specific blade in the future.. (Fig. 4.15)

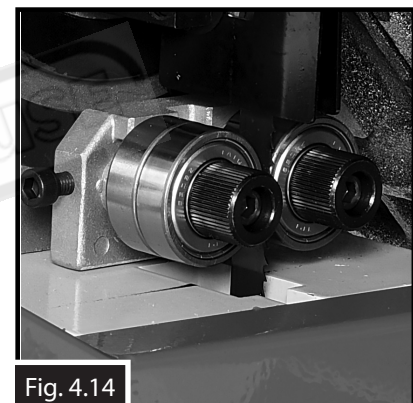

Fig. 4.14

WARNING: Too much tension can cause the band saw blade to break. Too little tension can cause the driven band saw wheel to slip and the saw blade to stop.

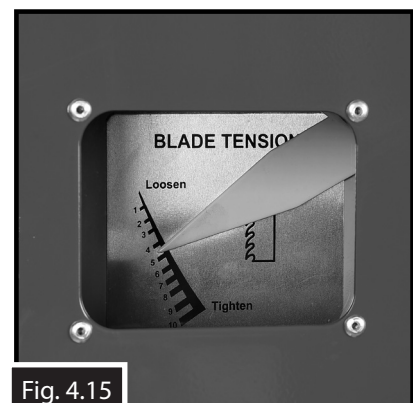

Fig. 4.15

9. Re-adjust the blade guides as described in Blade Guide Adjustment beginning on Page 22

4.9 BLADE TRACKING

To operate correctly, the saw blade does needs to run in the centre of the rubber tyre. If the blade rides in the centre of the upper wheel and is centred on the peak of the wheel crown, then the band-saw is tracking correctly and no adjustment is needed. If the blade does not ride in the centre of the upper wheel and is not centred on the peak of the wheel crown, then adjustment is required.

To check or adjust the tracking:

1. DISCONNECT THE MACHINE FROM THE POWER
2. Open the upper and lower covers. (Fig. 4.16)
3. Adjust the top and bottom guides so that are not touching the blade.
4. Make sure that the blade has been tensioned as per the instructions on Page 15.

CAUTION *The cast iron spokes of the upper wheel may have sharp burrs and the blade teeth may extend beyond the edge of the wheel, creating a laceration hazard. Be careful when turning the wheels by hand.*

5. Turn the upper wheel by hand around two to three times to see how the blade is tracking.
6. Loosen the lock lever (Fig. 4.17) so that the blade tracking knob can rotate.
7. Manually rotate the upper wheel, taking care not to touch the blade. At the same time turn the adjusting knob (Fig. 4.17) clockwise or anticlockwise until the saw blade tracks centred on the rubber tyre.
8. After adjustment, re-tighten the tracking lock lever and close the cover.

Fine Trackig Adjustment

During setup, the blade was tracked without the machine connected to power. In this procedure, the bandsaw is turned ON to perform fine blade tracking. Make small changes with the blade tracking knob as you monitor the effect on the blade tracking. Close the wheel covers and turn the bandsaw ON. Observe the blade tracking path through the clear window on the right edge of the bandsaw, (Fig. 4.18) Using the tracking controls, adjust the blade so that it tracks on the center of the wheel. Tighten the tracking lock to secure the setting.



FIG. 4.16

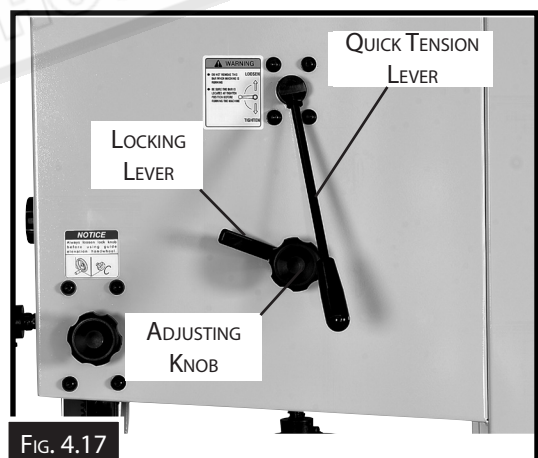

FIG. 4.17

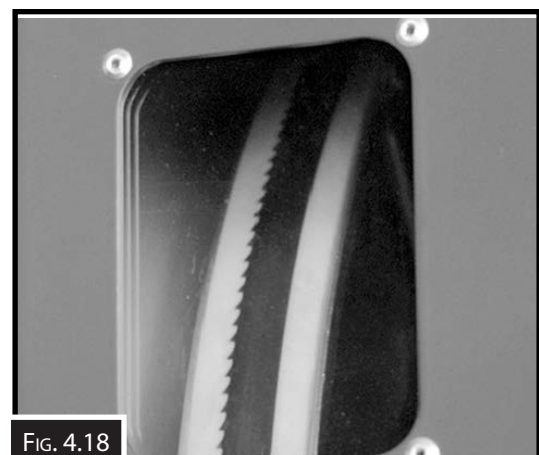

FIG. 4.18

4.10 TABLE STOP CALIBRATION

After tilting the table the adjustable positive stop allows the table to be reset 90° to the blade.

To set the positive stop:

1. DISCONNECT BAND SAW FROM POWER!
2. Adjust the blade tension see Page 15 until the blade tension is correct or matches the predetermined setting on the tension scale.
3. Loosen the hex nut that locks the positive stop bolt in place and loosen the table tilt hand knobs.
4. Raise the guide post and place a machinist's square on the table next to the side of the blade, as illustrated in Fig. 4.19. Adjust the table square with the blade, then secure with the table tilt knobs.
5. Adjust the positive stop bolt to the table. (Fig. 4.20)
6. Secure the positive stop bolt by tightening the hex nut against the trunnion bracket.
7. Check the adjustment for accuracy once you have tightened the hex nut.

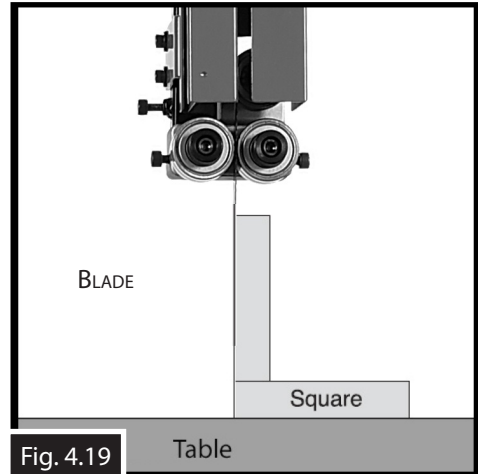

Fig. 4.19

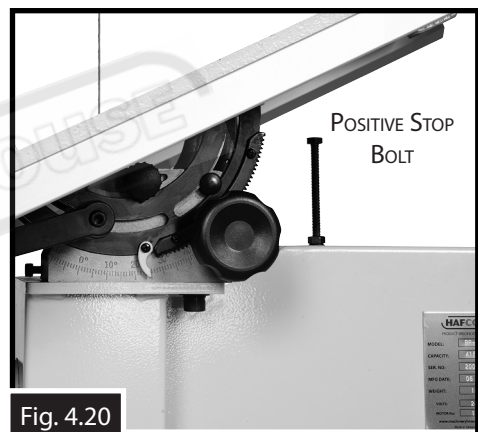

Fig. 4.20

4.11 TEST RUN

Once the assembly is complete, test run your machine to make sure it runs properly. If, during the test run, you cannot easily locate the source of an unusual noise or vibration, stop the machine immediately, then review the Troubleshooting section on Page 23.

If you still cannot remedy a problem, contact your distributor. The test procedure is as follows.

1. Make sure you have read the safety instructions at the beginning of the manual and that the machine is set up properly, including Blade Tracking above.
2. Make sure all tools and objects used during setup have been cleared away from the machine.
3. Connect the machine to the power source.
4. Turn the machine ON.
5. Listen and watch for abnormal noises or actions. The machine should run smoothly with little or no vibration or rubbing noises. — Strange or unusual noises must be investigated and corrected before operating the machine further. Always disconnect the machine from power when investigating or correcting potential problems.
6. Turn the machine OFF

5. OPERATION

5.1 Basic Controls

Use the descriptions below to become familiar with the basic controls of your machine.

Blade Tension Hand Wheel: Adjusts the tension on the blade. (Fig. 5.1)

Blade Tracking Adjustment Knob: Adjusts the blade tracking. (Fig. 5.2)

Blade Tension Quick Release: Quickly tensions or releases the blade without losing its setting. (Fig.5.2)

Guide Post Adjustment Knob: Raises and lowers the blade guide post. (Fig. 5.3)

Guide Post Locking Knob: Locks the blade guide post. (Fig. 5.3)

ON/OFF Switch: Starts and stops the blade motor. (Fig. 5.4)

Mitre Gauge Lock Handle: Locks the mitre gauge at the current setting. (Fig. 5.5)

Fence Lock Lever: Locks the fence at its current position. (Fig. 5.5)

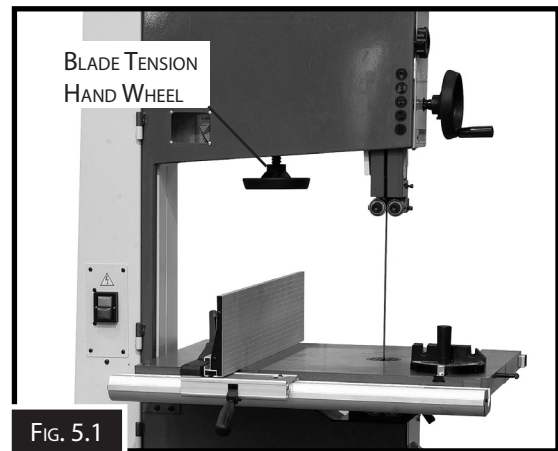

FIG. 5.1

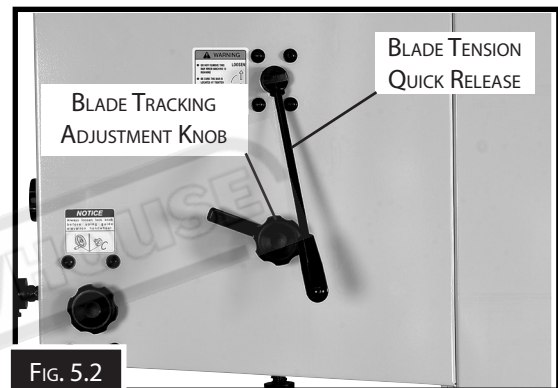

FIG. 5.2

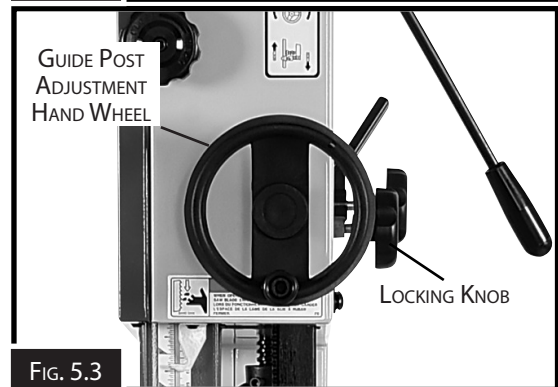

FIG. 5.3

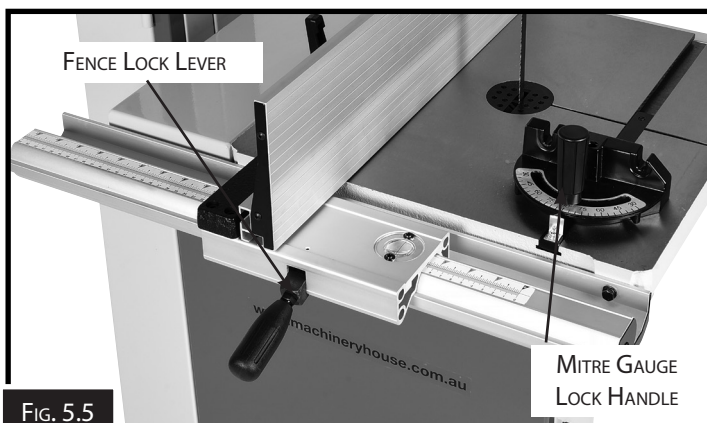

FIG. 5.5

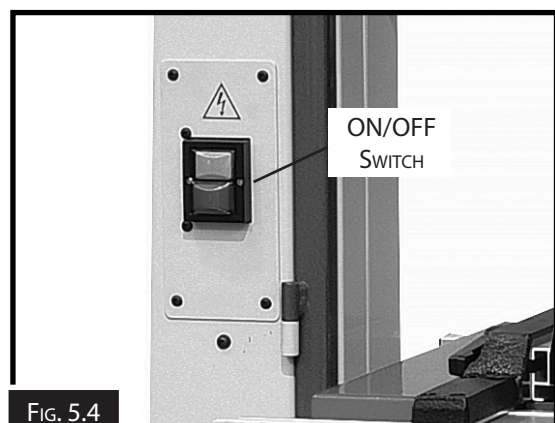

FIG. 5.4

5.2 BLADE INFORMATION

Selecting the right blade requires a knowledge of the various blade characteristics mentioned below, the type of material you plan to cut, and the type of cut you are going to perform.

Blade Length

The blade length is measured by the circumference. Blade lengths are usually unique to the brand of your band saw and the distance between wheels. The chart below displays the blade length for the model and available blades.

NOTE: "Available Blades" lists the stocked blades but other sizes and blade teeth are available from most local saw blade manufacturers

MODEL	BLADE LENGTH	AVAILABLE BLADES.
BP-430A	3340MM	6 TPI SKU: W433A 3 TPI SKU: W433B 3 TPI NARROW SKU: W433C
BP-480A	3630MM	6 TPI SKU: W434A 3 TPI SKU: W434B

Blade Width

Measured from the back of the blade to the tip of the blade tooth (the widest point), blade width is often the first consideration given to blade selection. Blade width dictates the largest and smallest curve that can be cut, as well as how accurately it can cut a straight line.

Curve Cutting:

View the chart in Fig. 5.6 to determine the correct blade width for curve cutting. Determine the smallest radius curve that will be cut on the work piece and use the corresponding blade width. (Fig. 5.6)

Straight Cutting:

Use the largest width blade available. (See specifications on Page 4 for the maximum width for the model)

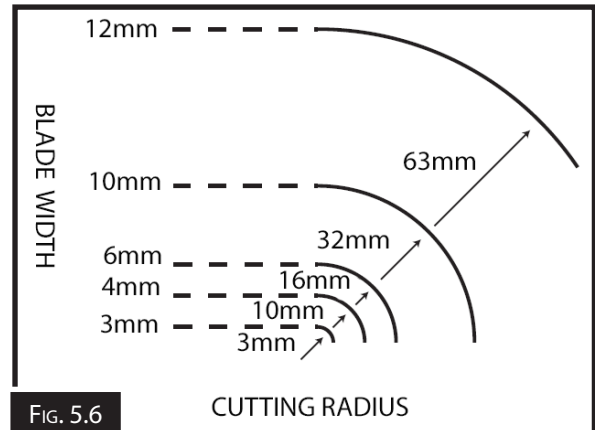

FIG. 5.6

Tooth Style

When selecting blades, another option to consider is the shape, gullet size, teeth set and teeth angle—otherwise known as "Tooth Style." As shown Fig.5.7

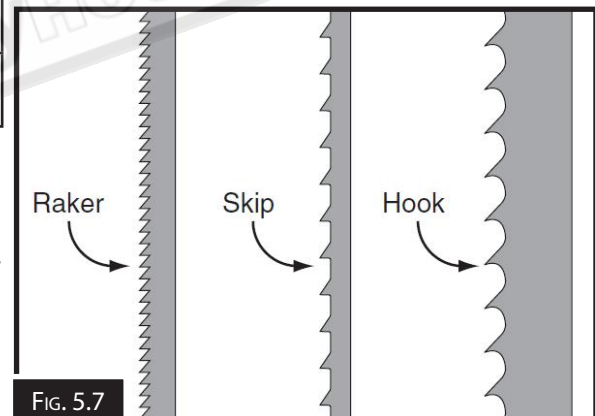

FIG. 5.7

Raker: Considered to be the standard because the tooth size and shape are the same as the tooth gullet.

Skip: This style is similar to a raker blade but is missing every other tooth. Skip toothed blades have a larger gullet, and cut faster.

Hook: This teeth type have a positive angle (downward) allows them to dig into the material. The gullets are usually rounded for easier waste removal. Excellent for the tough demands and ripping thick material.

5.3 CHANGING THE BLADE

To remove the blade:

1. DISCONNECT POWER FROM THE BAND SAW
2. Release the blade tension by turning the blade tension hand wheel (Fig. 5.8) or turn the quick release lever to the left.(Fig. 5.9)
4. Remove the table insert and the table pin. Adjust the upper and lower guide bearings as far away as possible from the blade.
5. Open the upper and lower wheel covers, (Fig. 5.10) Put on leather gloves and slide the blade off both wheels.
6. Rotate the blade 90° and slide it through the slot in the table.
7. Take the new blade and slide it through the table slot, ensuring that the teeth are pointing down toward the table.

NOTE: *If the teeth will not point downward in any orientation, the blade is inside-out. Put on leather gloves, and remove the blade, and twist it right side-out.*

8. Slip the blade through the guides, and mount it on the upper and lower wheels.
9. Tighten the blade tension quick release.
10. Apply tension to the blade by turning the tension control knob. Rotate the upper wheel slowly by hand as tension is applied to allow the blade to centre itself on the wheel. Adjust tracking if needed.
11. Adjust tension as described Page 15.
12. Adjust the upper/lower guide bearings and the support bearings.
13. Close the wheel covers.
14. Replace the table insert and table pin, being sure not to use excessive force when inserting the table pin.

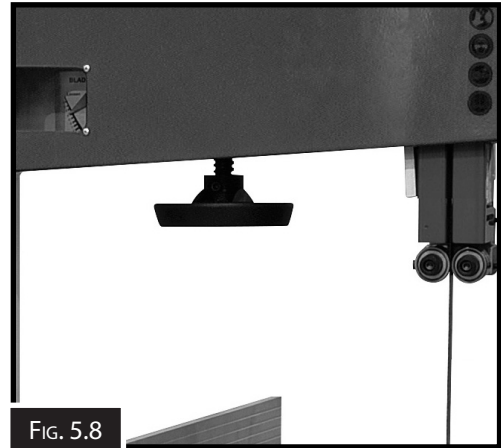

FIG. 5.8



FIG. 5.9

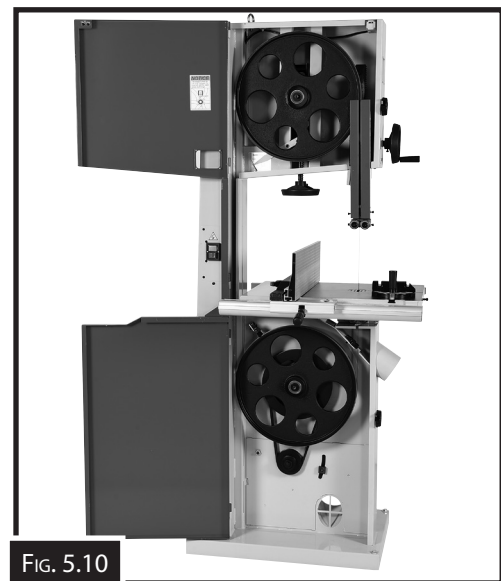

FIG. 5.10

CAUTION *All saw blades are dangerous and may cause personal injury. To reduce the risk of being injured, wear leather gloves when handling saw blades.*

5.4 ADJUSTING THE SPEED

The band saws listed in this manual are fitted with a pulley system that allows for two speeds to be available for the operation. Below are the details for adjusting the speeds.

To change the speed

1. DISCONNECT THE MACHINE FROM THE POWER SUPPLY
2. With a hex key, loosen the motor positing clamp on the back of the machine. (Fig. 5.11)
3. Open the bottom door on the machine to gain access to the belt drive. (Fig. 5.12)
4. Move the V-belt from one set of pulleys to the other set.
5. Re-Clamp the motor, making sure that the V-belt has been tensioned correctly.

NOTE: A common speed for the band saw is about one 300 meters per minute. Wood can effectively be cut at much higher speeds, but you should keep it slower because it's safer.



FIG. 5.11



FIG. 5.12

5.5 TILTING THE TABLE

WARNING: Always be sure that the machine is switched off and unplugged before any adjustment is commenced.

Loosen the locking handle and adjust the table to the desired angle using the adjuster knob. Use the angle indicator scale to find the desired angle. The scale is only used as a guide. For very accurate angle use a protractor against the blade. Re-tighten the locking handle to secure the table.

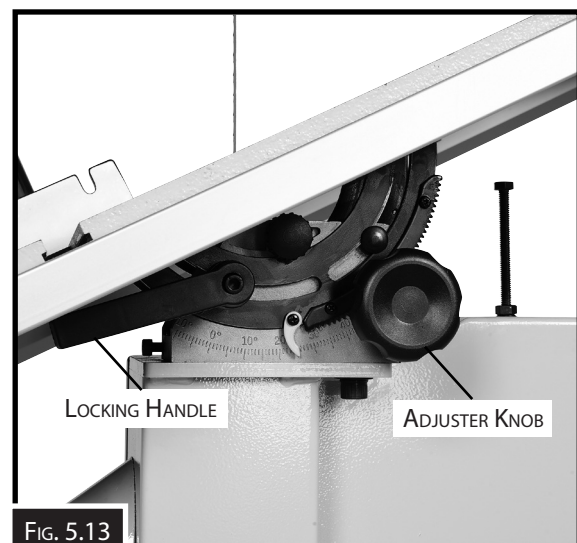

FIG. 5.13

5.6 ADJUSTING SUPPORT BEARINGS

The support bearings are positioned behind the blade for support during cutting operations. Proper adjustment of the support bearings is an important part of making accurate cuts. The procedure is as follows.

1. Make sure that the blade is tracking properly and that it is correctly tensioned.
2. DISCONNECT BAND SAW FROM POWER!
3. Familiarize yourself with the support bearing controls shown in Fig. 5.14
- A. Locks the bearing support roller in place after it has been moved back or forward.
- B. Locks the complete Blade Guide assembly. When unlocked the whole assembly can be moved forward or back when out of adjustment.
4. Loosen the socket head cap screw on the support bearing adjustment shaft. (A in Fig.5.14)
5. Adjust the support bearing 0.5mm away from the back of the blade, as illustrated in Fig. 5.15
6. Repeat Steps 4–6 for the lower support bearings.

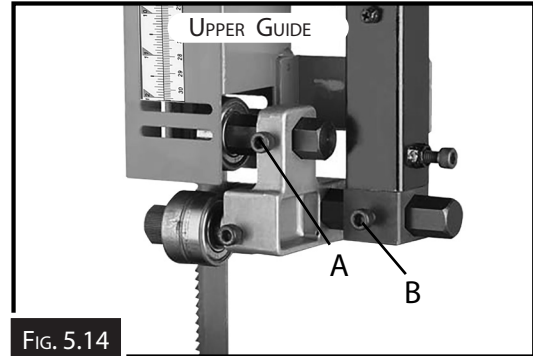

FIG. 5.14

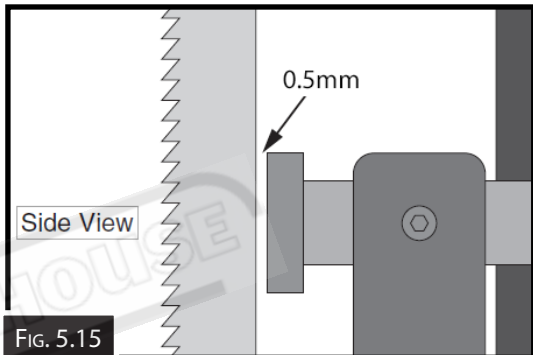

FIG. 5.15

4.5 BLADE GUIDE ADJUSTMENTS

The blade guides consist of an upper and lower set of ball bearings that provide side-to-side support to help keep the blade straight while cutting. The blade guides are designed to be adjusted side-to-side.

1. Make sure that the blade is tracking properly and that it is correctly tensioned.
 2. DISCONNECT BAND SAW FROM POWER!
 3. Familiarize yourself with the blade guide controls shown in Fig. 5.16.
 - C. The Socket head cap screws lock the side rollers in place after they have been moved towards or away from the side of the blade.
 - D. Rotate the cam that moves the roller in or out.
 4. Undo the socket head cap screw of the blade guide bearings. (C in Fig. 5.16)
 5. Using a feeler gauge rotate the bearings until 0.1mm away from the blade. (D in Fig. 5.16)
 6. Tighten the cap screw to lock the blade guide bearings in position.
- Repeat Step 4-6 for the lower guides.

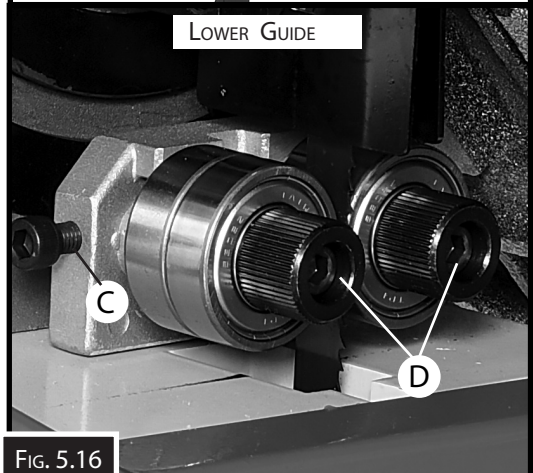
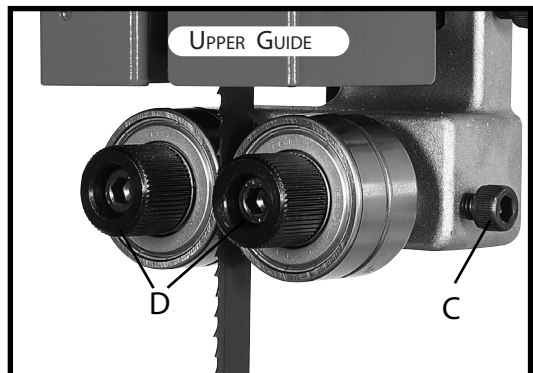

FIG. 5.16

6. MAINTENANCE

Review the troubleshooting and procedures in this section to fix or adjust your machine if a problem develops. If you need replacement parts or you are unsure of your repair skills, then contact your local distributor or service provider. **NOTE:** Hafco/Woodmaster advise that extension leads should not be used permanently, but recommend that the plug be placed directly in to a wall socket.

6.1 TROUBLESHOOTING

Symptom	Possible Cause	Possible Solution
Machine does not start or a breaker trips.	<ol style="list-style-type: none"> 1. Plug/receptacle is at fault or wired incorrectly. 2. Motor connection wired incorrectly. 3. Power supply is at fault/switched OFF. 4. Motor ON/OFF switch is at fault. 5. Wiring is open/has high resistance. 6. Start capacitor is at fault. 7. Motor is at fault. 	<ol style="list-style-type: none"> 1. Test for good contact or correct the wiring. 2. Correct motor wiring connections 3. Have a qualified electrician check the voltage at the meter box, and that connections are not faulty. 4. Replace faulty ON/OFF switch. 5. Check for broken wires or corroded connections, and repair/replace as necessary. 6. Test/replace if faulty. 7. Repair/replace.
Machine stalls or is underpowered	<ol style="list-style-type: none"> 1. Wrong workpiece material (wood). 2. Processing speed too fast for task. 3. Low power supply voltage. 4. Run capacitor is at fault. 5. V-belt slipping. 6. Blade is slipping on wheels. 7. Motor bearings are at fault. 8. Motor has overheated. 9. Motor is at fault. 	<ol style="list-style-type: none"> 1. Use wood with correct moisture content, without glues, and little pitch/resins. 2. Decrease processing speed. 3. Ensure all hot lines have correct voltage on all phase. 4. Repair/replace. 5. Replace bad V-belt, align pulleys, and re-tension 6. Adjust blade tracking and tension. 7. Test by rotating shaft; rotational grinding/ loose shaft requires bearing replacement. 8. Clean off motor, let cool, and reduce work load. 9. Repair/replace.
Machine has vibration or noisy operation when running.	<ol style="list-style-type: none"> 1. Motor or component is loose. 2. V-belt worn or loose. 3. Motor fan is rubbing on fan cover. 4. Pulley is loose. 5. Machine is incorrectly mounted or sits unevenly on the floor. 6. Motor bearings are at fault. 7. Blade weld is at fault or teeth are broken. 8. Worn arbor bearings. 9. Wheels not aligned correctly. 10. Tyres incorrectly installed. 11. Bent or worn out blade. 12. Wheels out of balance. 	<ol style="list-style-type: none"> 1. Inspect/replace stripped or damaged bolts/nuts, and re-tighten with thread locking fluid. 2. Inspect/replace belt . 3. Replace dented fan cover 4. Realign/replace shaft, pulley, set screw, and key as required. 5. Adjust the feet on the bottom of the stand; relocate machine. 6. Test by rotating shaft and replace bearing if required 7. Replace blade 8. Check/replace arbor bearings. 9. Adjust wheel alignment (Page 22) 10. Re-install tires. 11. Replace blade. 12. Replace wheels.

Symptom	Possible Cause	Possible Solution
Machine slows when operating	1. Applying too much pressure to workpiece. 2. Blade is dull.	1. Feed workpiece slower and in a smooth motion 2.. Replace blade
Ticking sound when the saw is running.	1. Blade weld contacting support bearing. 2. Blade weld may be failing	1. Use file or stone to smooth and round the back of the blade. 2. Inspect and replace blade if necessary
Blade touching table insert.	1. Excessive side pressure when cutting. 2. Table improperly adjusted	1. Reduce side pressure. 2. Adjust table
Vibration when cutting.	1. Loose or damaged blade.	1. Tighten or replace blade
Burn marks on the edge of the cut.	1. Too much side pressure when feeding workpiece. 2. Blade too wide for size of radius being cut	1. Feed workpiece straight into the blade. 2. Install a smaller width blade/increase blade tension.
Rough or poor quality cuts.	1. Blade lead.	1. Blade lead is commonly caused by too fast feed rate, a dull blade, or improper tension

6.2 WHEEL ALIGNMENT

Wheel alignment is one of the most important issues to ensure the best performance from your band saw. Over time vibration, and wandering blades cause tyre wear. This can be considerably reduced when the wheels are properly aligned. The procedure is as follows.

1. Remove the fence and table, then open both the wheel covers.
2. Make sure the guide blocks and rear support bearings have been moved away from the blade, then tighten your blade to the tension that it will be used during operation.
4. Place the straight edges against both wheels in the positions shown in Fig. 6.1
5. The hub on the bottom wheel allows you to adjust the lower wheel in the desired direction. By loosening the lock nuts and turning all the grub screws clockwise in equal amounts, pushes the wheel forward. Turning all the grub screws counter clockwise moves the wheel towards the back of the machine. When the grub screws are adjusted individually, each grub screw controls the direction that the wheel tilts. (Fig. 6.2)
6. When finished with the adjustment the locked nuts must be tightened.

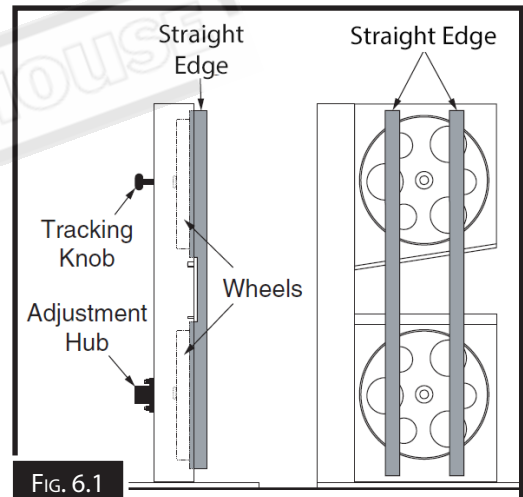

FIG. 6.1

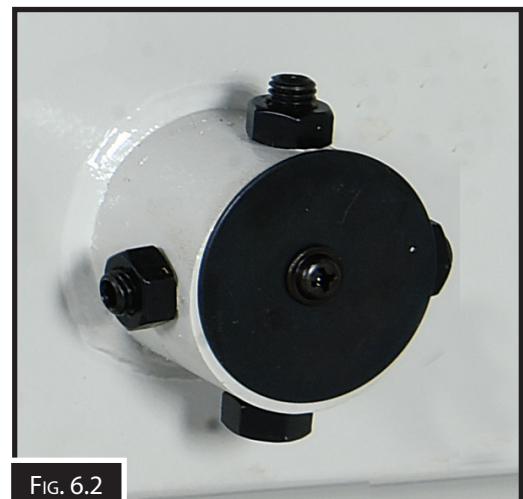

FIG. 6.2

SPARE PARTS SECTION

WOOD BAND SAW

Models

BP-430A BP-480A

Order Code W4330, Order Code W4340

Edition No : BP-430A,480A-1

Date of Issue : 11/2020

The following section covers the spare parts diagrams and lists that were current at the time this manual was originally printed. Due to continuous improvements of the machine, changes may be made at any time without notification.

HOW TO ORDER SPARE PARTS

1. Have your machines **model number, serial number & date of manufacture** on hand, these can be found on the specification plate mounted on the machine
2. A scanned copy of your parts list/diagram with required spare part/s identified.

NOTE: SOME PARTS MAY ONLY BE AVAILABLE AS AN ASSEMBLY

3. Go to www.machineryhouse.com.au/contactus and fill out the inquiry form attaching a copy of scanned parts list.

CONTENTS

BP-430A Machine Spare Parts Diagram.....	26
BP-430A Machine Spare Parts List.....	28
BP-430A Fence Spare Parts Diagram.....	32
BP-430A Fence Spare Parts List.....	33
BP-430A Upper Guide Parts Diagram & List.....	34
BP-430A Lower Guide Parts Diagram & List.....	35
BP-480A Machine Spare Parts Diagram.....	36
BP-480A Machine Spare Parts List.....	38
BP-480A Fence Spare Parts Diagram.....	42
BP-480A Fence Spare Parts List.....	43
BP-480A Upper Guide Parts Diagram & List.....	43
BP-480A Lower Guide Parts Diagram & List.....	45
Electrical Drawing.....	46

BP-430A MACHINE SPARE PARTS DIAGRAM

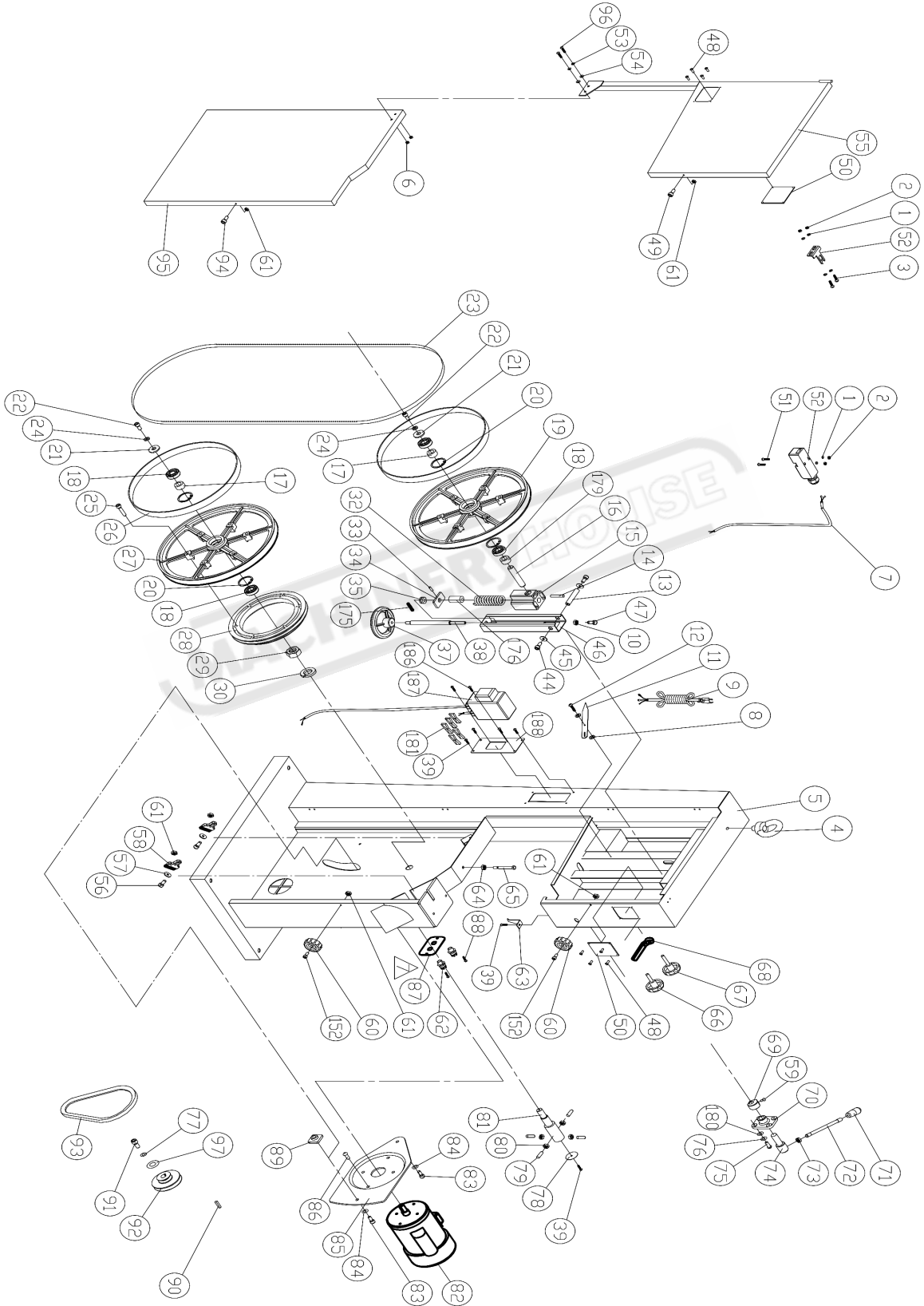

BP-430A MACHINE SPARE PARTS DIAGRAM

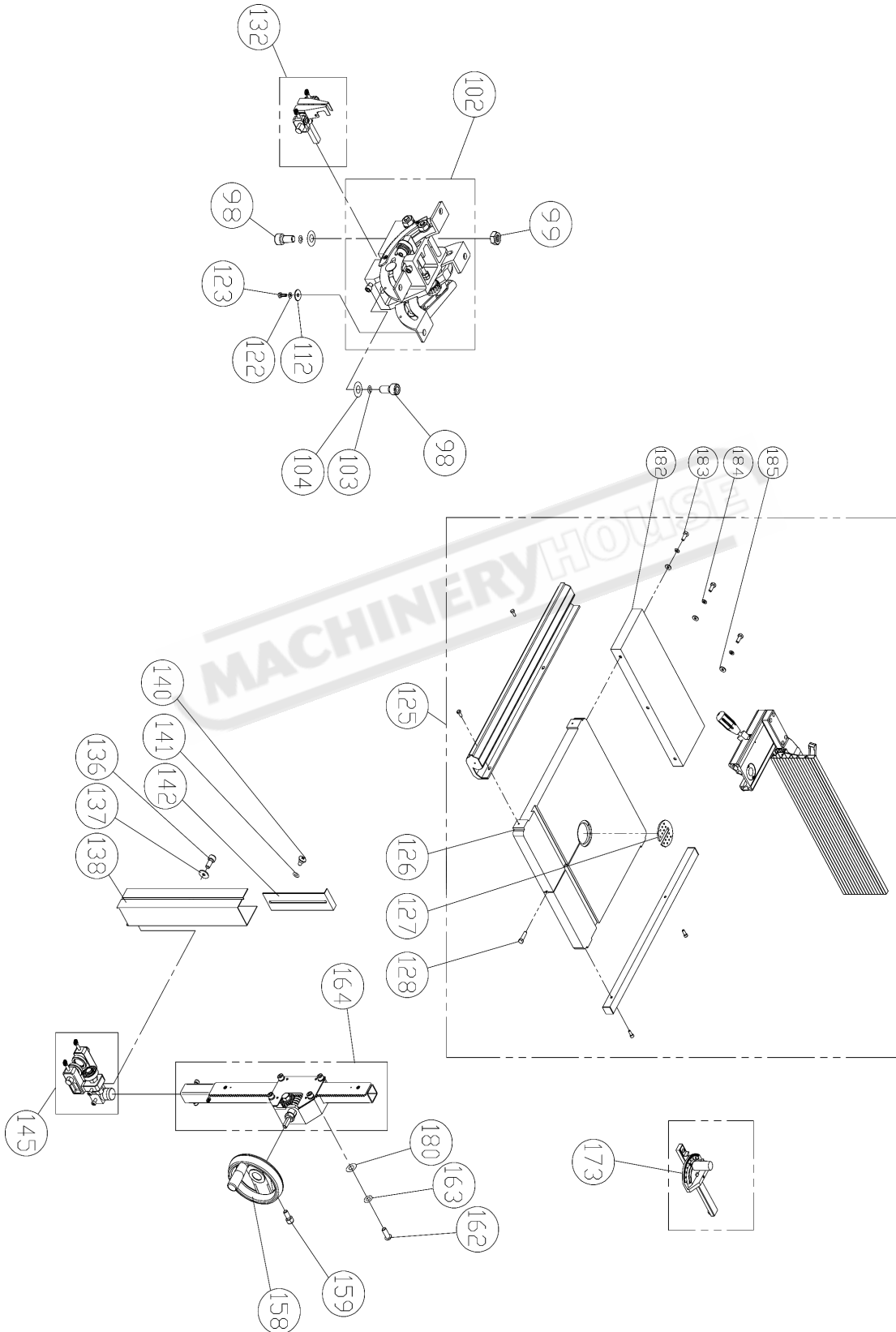

BP-430A MACHINE SPARE PARTS LIST

No.	Part No.	Description	Specification	Qty
1	WF040808	FLAT WASHER	M4x8	6
2	NH040700	NUT	M4	4
3	SP040200	PAN HEAD SCREW	M4x8	2
4	995101	RING	M10	1
5	136161	MACHINE BODY		1
6	NF050800	NUT	M5	2
7	IC135042	SWITCH CORD		1
8	WF061310	FLAT WASHER	M6x13	2
9	IC135001	POWER CORD	3P+G	1
10	NH061000	NUT	M6	1
11	135040	POINTER		1
12	135073	STEP SCREW		1
13	135012	UPPER SHAFT		1
14	PS053600	SPRING PIN	Ø5x36	1
15	135017	UPPER WHEEL SHAFT HINGE		1
16	135066	UPPER WHEEL SHAFT		1
17	135039	BUSHING		2
18	BB620403	BALL BEARING	6204LLU	4
19	135024	UPPER WHEEL	Ø 17"	1
20	RR470000	RETAINING RING	R47	4
21	WF083030	FLAT WASHER	M8x30	2
22	SR089400	HEX SOCKET BOLT	M8x16	2
23	135075	SAW BLADE	6PTI 3352.8x1/2"0.5mm	1
24	WS080000	SPRING WASHER	M8	2
25	SR060600	HEX SOCKET BOLT	M6x30	6
26	135105	TIRE		2
27	135014	LOWER WHEEL	Ø 17"	1
28	135007	IDLE PULLEY		1
29	NH633801	NUT	1"-14 UNF	1
30	WS630000	SPRING WASHER	1"	1
31				
32	135032	SPRING	Ø3x16	1
33	PS031600	SPRING PIN		1
34	135042	LOCATE BLOCK	51201	1
35	994301	BEARING		1
36				
37	135002	HANDLE WHEEL		1
38	135003	ADJUSTING BOLT	M5x10	1
39	SF050200	PAN HEAD BOLT W/FLANGE		8

BP-430A MACHINE SPARE PARTS LIST

No.	Part No.	Description	Specification	Qty
40				
41				
42				
43				
44	SR089400	HEX SOCKET BOLT	M8x16	2
45	WF083030	FLAT WASHER	M8x30	2
46	135016	UPPER WHEEL SLIDING BRACKET		1
47	SR060500	HEX SOCKET BOLT	M6x25	1
48	BR000044	RIVET	Ø3.2x10	8
49	SR060200	HEX SOCKET BOLT	M6x10	1
50	135004	LIMPID PIECE		2
51	SF040700	PAN HEAD BOLT W/FLANGE	M4x35	2
52	136475	DOOR LATCH SWITCH(ASM)	AZD-S11	1
53	WS050000	SPRING WASHER	M5	2
54	WF051210	FLAT WASHER	M5x12	2
55	136164	UPPER WHEEL COVER		1
56	SH060500	HEX HEAD BOLT	M6x25	2
57	WF061310	FLAT WASHER	M6x13	2
58	135051	BRUSH		2
59	SR060500	HEX SOCKET BOLT	M6x25	1
60	135041	KNOB		2
61	NL061000	NYLON NUT	M6	6
62	709416	STRAIN RELIEF	M16	2
63	135011	HEIGHT POINTER		1
64	NH081300	NUT	M8	1
65	SH081800	HEX HEAD BOLT	M8x90	1
66	135022	KNOB SCREW	M10x20	1
67	135020	KNOB SCREW	M10x53	1
68	135028	LOCATE HANDLE	M10	1
69	135030	CAM		1
70	135038	LOCATE BLOCK		1
71	620021	KNOB		1
72	620020	LEVER ROD		1
73	NH121900	NUT	M12	1
74	135036	SHAFT		1
75	SJ080400	HEX SOCKET HEAD SCREW	M8x20	4
76	WS080000	SPRING WASHER	M8	4
77	WS080000	SPRING WASHER	M8	1
78	135013	COVER		1
79	SS080400	SET BOLT	M8x20	4
80	NH081300	NUT	M8	4

BP-430A MACHINE SPARE PARTS LIST

No.	Part No.	Description	Specification	Qty
81	135005	LOWER WHEEL SHAFT		1
82	MH135001	MOTOR	1 HP	1
83	SR100500	HEX SOCKET BOLT	M10x25	2
84	WS100000	SPRING WASHER	M10	2
85	135064	MOTOR BRACKET		1
86	SJ080400	HEX SOCKET HEAD SCREW	M8x20	4
87	135081	PLATE		1
88	SF050200	PAN HEAD BOLT W/FLANGE	M5x10	2
89	135065	LOCATE BLOCK		1
90	KS050535	KEY	5x5x35	1
91	SH080402	HEX HEAD BOLT	M8x20(L.H)	1
92	135008	MOTOR PULLEY		1
93	LA420000	V-BELT	A42	1
94	SR060200	HEX SOCKET BOLT	M6x10	1
95	136165	LOWER WHEEL COVER		1
96	SJ059400	HEX SOCKET BOTTOM HEAD SCREW	M5x16	2
97	WF083030	FLAT WASHER	M8x30	1
98	SR100700	HEX SOCKET BOLT	M10x35	2
99	NH101700	NUT	M10	1
100				
101				
102	AB135021	TRUNNION SUPPORT BRACKET(ASM)		1
103	WS100000	SPRING WASHER	M10	2
104	WF102325	FLAT WASHER	M10x23	2
105				
106				
107				
108				
109				
110				
111				
112	WF081820	FLAT WASHER	M8x18	4
122	WS080000	SPRING WASHER	M8	4
123	SH089400	HEX HEAD BOLT	M8X16	4
124				
125	QF198021-B	17" FENCE SET		1
126	135126	TABLE		1
127	135010	TABLE INSERT		1
128	100038	TABLE PIN		1
132	AB135059	LOWER BLADE GUIDE SUPPORT(ASM)		1
135	135035	RIGHT COVER		1
136	SR050200	HEX SOCKET BOLT	M5X10	2
137	WF051210	FLAT WASHER	M5X12	2
138	135034	PROTECT COVER(ASM)		1
140	135073	STEP SCREW		1

BP-430A MACHINE SPARE PARTS LIST

No.	Part No.	Description	Specification	Qty
141	135054	FIBER WASHER	4-13x6x1.2	1
142	135037	SLIDING PLATE		1
143				
144				
145	AB135055	UPPER BLADE GUIDE SUPPORT(ASM)		1
146				
152	SR060400	HEX SOCKET BOLT	M6x20	2
153				
154				
155				
156				
157				
158	135006	HANDLE WHEEL		1
159	SR060400	HEX SOCKET BOLT	M6x20	1
160				
161				
162	SJ080400	HEX SOCKET BOTOM HEAD SCREW	M8x20	4
163	WS080000	SPRING WASHER	M8	4
164	AB135050	GUIDE BRACKET(ASM)		1
173	AB198101	MITER GAUGE ASS'Y		
174				
175	SS069300	SET SCREW	M6x10	1
176	135067	BUSHING		1
177				
178				
179	612112	BUSHING		1
180	WF081820	FLAT WASHER	M8x18	4
181	136019	WIRE CONECTOR	224-201	5
182	135127	EXTEND TABLE		1
183	SH080400	HEX HEAD BOLT	M8x20	3
184	WS080000	SPRING WASHER	M8	3
185	WF081818	FLAT WASHER	M8xφ18	3
186	ST039304	TAPPING SCREW	M3.5x12(AB)	2
187	136017B	BRAKING SWITCH	K400	1
188	135099	SWITCH PLATE		1

NOTE: SOME INDIVIDUAL PARTS MAY ONLY BE AVAILABLE AS AN ASSEMBLY

BP-430A FENCE SPARE PARTS DIAGRAM

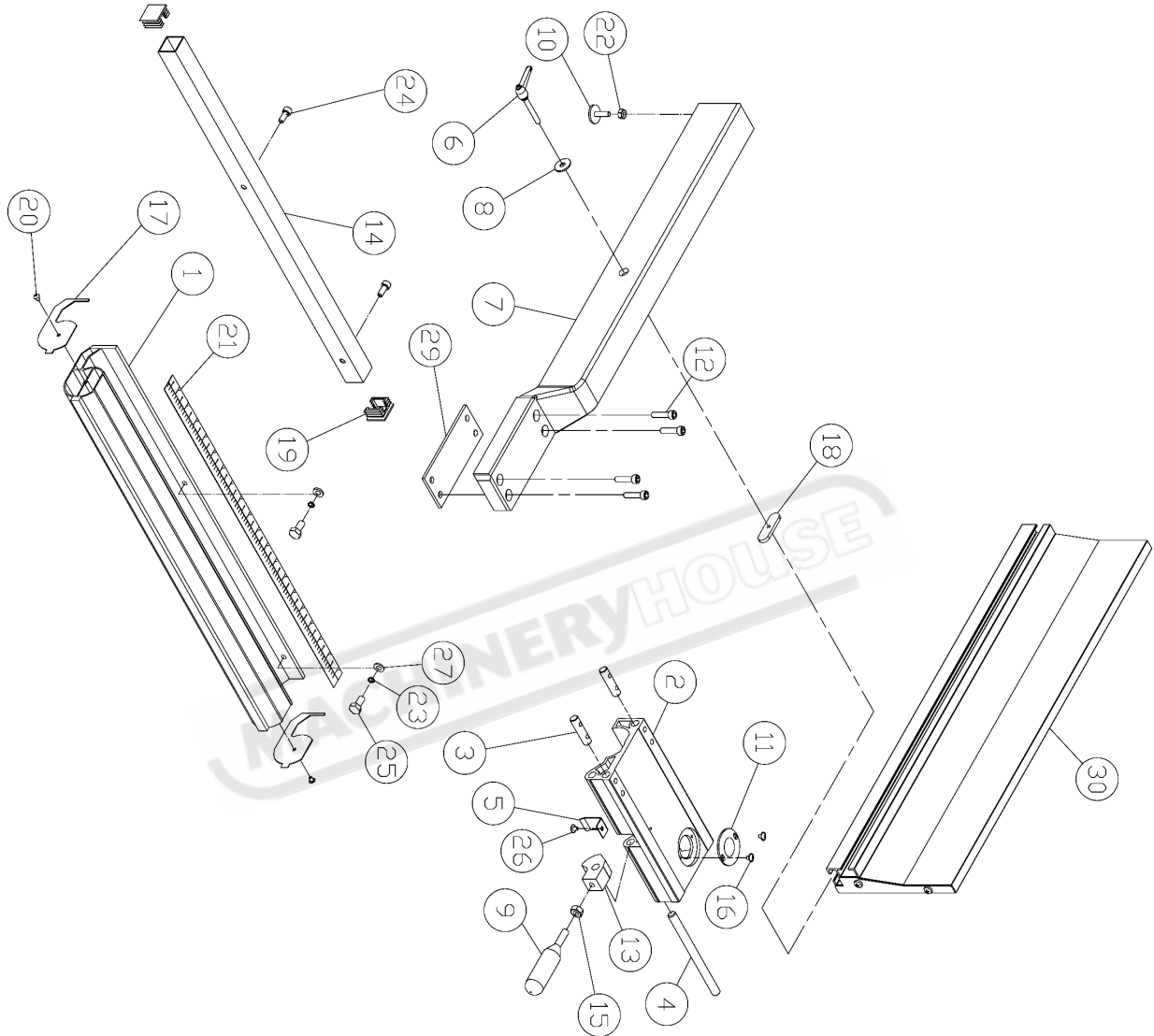

BP-430A FENCE SPARE PARTS LIST

No.	Part No.	Description	Specification	Qty
30	ACI98082	FENCE (AL)	590	
29	198008	BRACKET	T=3	
27	WF061310	FLAT WASHER	M6x13	1
26	SF049200	PAN HEAD BOLT W/FLANGE	M4x8	2
25	SH060400	HEX HEAD BOLT	M6x20	1
24	SR069400	HEX SOCKET BOLT	M6x16	2
23	wS060000	SPRING WASHER	M6	2
22	NH061000	NUT	M6	2
21	LM001035	SCALE		
20	ST039300	TAPPING SCREW	M3.5x12	
19	198016	PLUGGED		2
18	200527	MOVING PLATE		2
17	198014	GUARD PIECE		
16	SF049100	PAN HEAD BOLT W/FLANGE	M4x6	2
15	NH081300	NUT	MB	2
14	198020	SQUARE TUBE	640	
13	198004	FIXED LUMP		
12	SR060500	HEX SOCKET BOLT	M6x25	
11	198007	CONVEX		4
10	198012	ADJUST SCREW		
09	198013	HANDLE		
08	WF082320	FLAT WASHER	M8xØ23	
07	198077	SUPPORT TUBE	590	
06	198074	LOCK KNOB	M8x44	
05	198006	SPRING WASHER		
04	198005	SHAFT		
03	198003	FIXED SHAFT		
02	198002	ADJUST BASE		2
01	198018	FIXED BASE	640	1

NOTE: SOME INDIVIDUAL PARTS MAY ONLY BE AVAILABLE AS AN ASSEMBLY

BP-430A UPPER GUIDE SPARE PARTS DIAGRAM

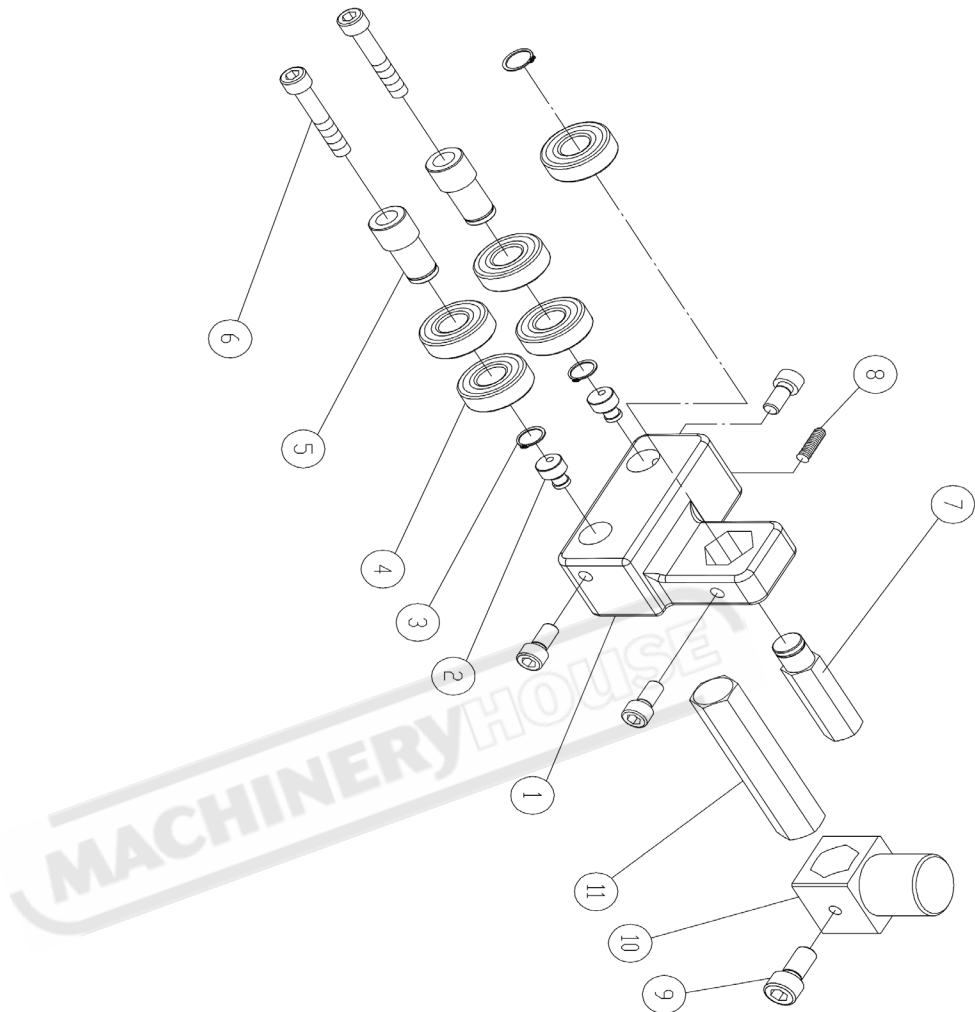

BP-430A UPPER GUIDE SPARE PARTS LIST

No.	Part No.	Description	Specification	Qty
1	135091	UPPER BLADE GUIDE SUPPORT		1
2	13590	BIAS SHAFT		2
3	RS150000	RING	S15	3
4	BB620202A	BALL BEARING	6202ZZ	5
5	136445	HANDLE BUSHING		2
6	SR060703	HEX SOCKET BOLT	M6x35	2
7	135060	UPPER SPACING SLEEVE		
8	SS060200	SET BOLT	M6x10	
9	SR069400	HEX SOCKET BOLT	M6x16	4
10	135057	UPPER GUIDE SUUPPORT BLOCK		
11	135053	ADJUST BAR		

NOTE: SOME INDIVIDUAL PARTS MAY ONLY BE AVAILABLE AS AN ASSEMBLY

BP-430A LOWER GUIDE SPARE PARTS DIAGRAM

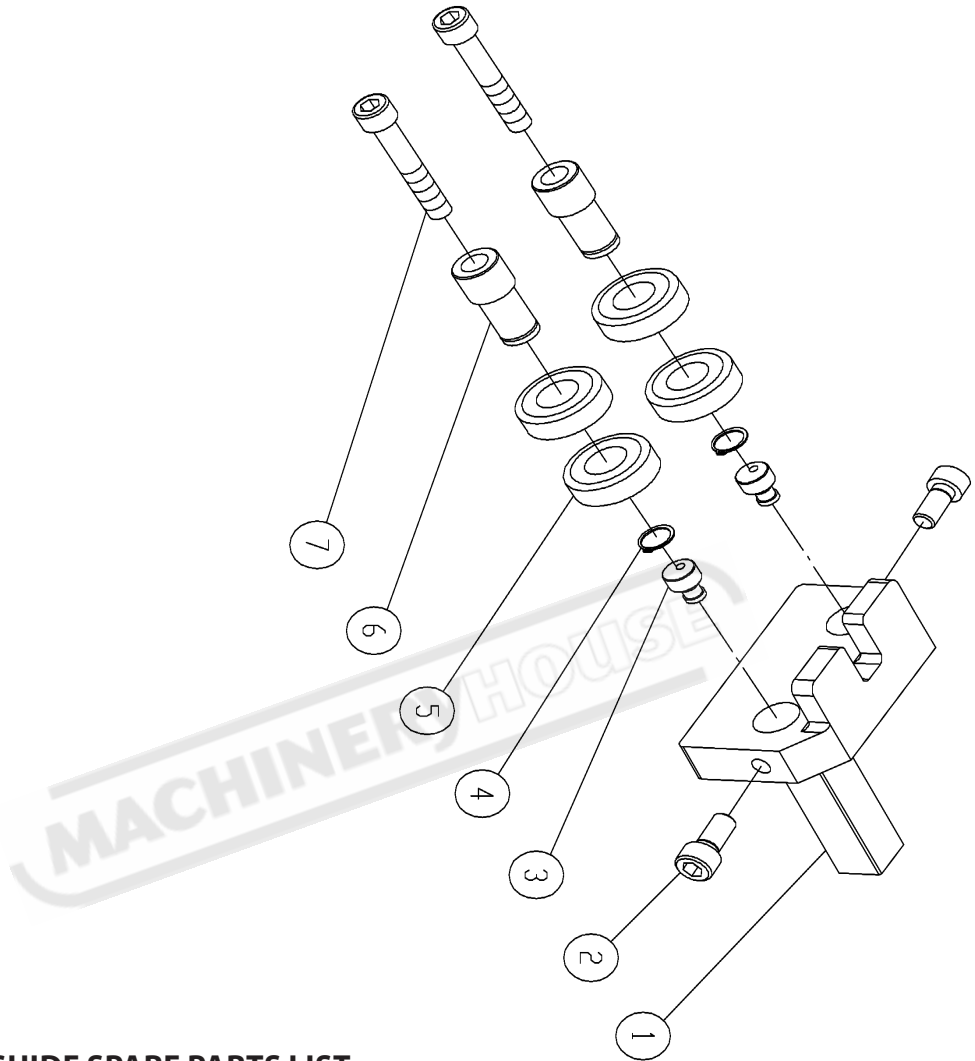

BP-430A LOWER GUIDE SPARE PARTS LIST

No.	Part No.	Description	Specification	Qty
1	135091	UPPER BLADE GUIDE SUPPORT		1
2	135090	BIAS SHAFT		2
3	RS150000	RING	S15	3
4	BB620202A	BALL BEARING	6202ZZ	5
5	136445	HANDLE BUSHING		2
6	SR060703	HEX SOCKET BOLT	M6x35	2
7	135060	UPPER SPACING SLEEVE		
8	SS060200	SET BOLT	M6x10	
9	SR069400	HEX SOCKET BOLT	M6x16	4
10	135057	UPPER GUIDE SUUPPORT BLOCK		
11	135053	ADJUST BAR		

NOTE: SOME INDIVIDUAL PARTS MAY ONLY BE AVAILABLE AS AN ASSEMBLY

BP-480A MACHINE SPARE PARTS DIAGRAM

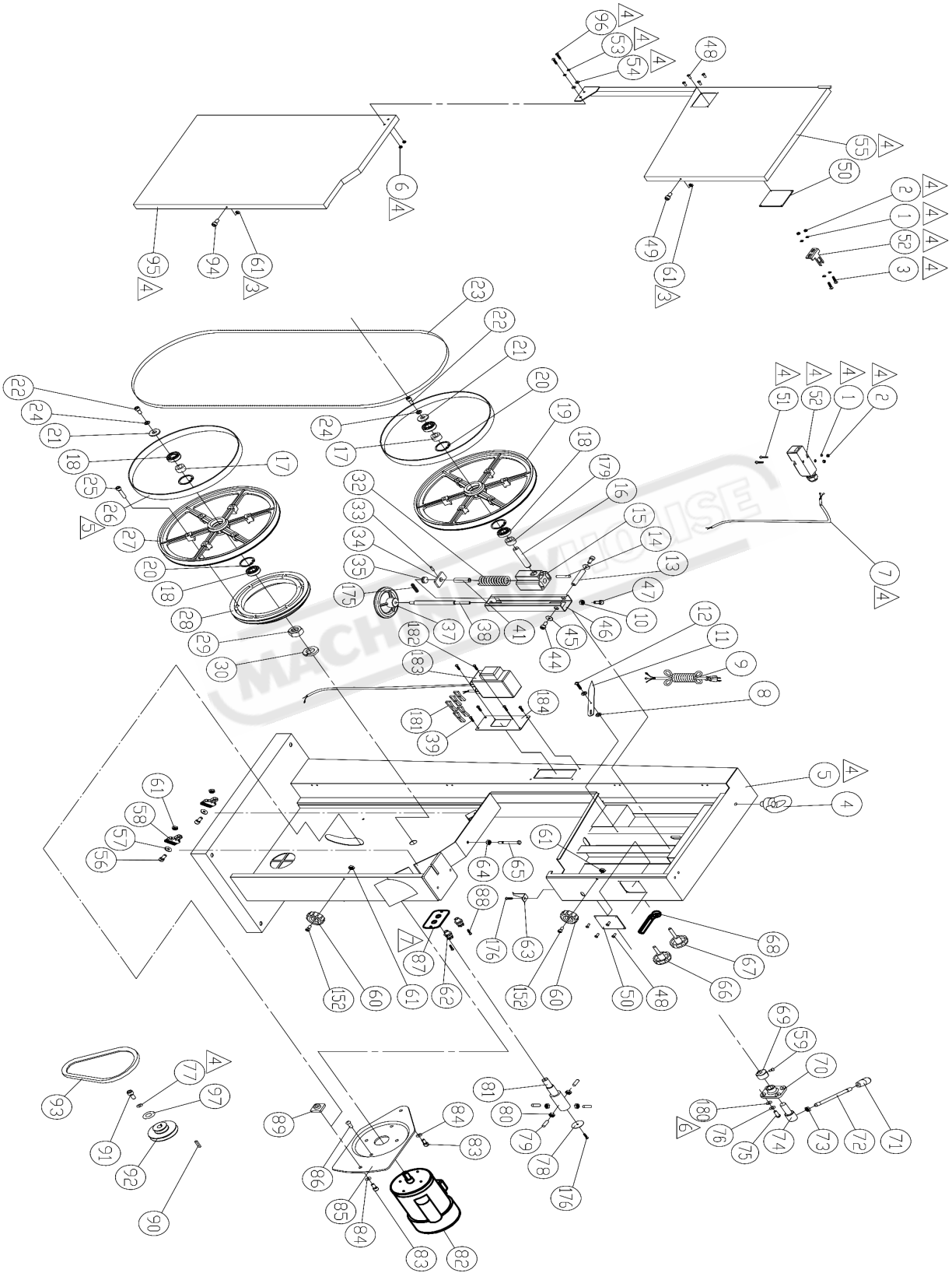

BP-480A MACHINE SPARE PARTS DIAGRAM

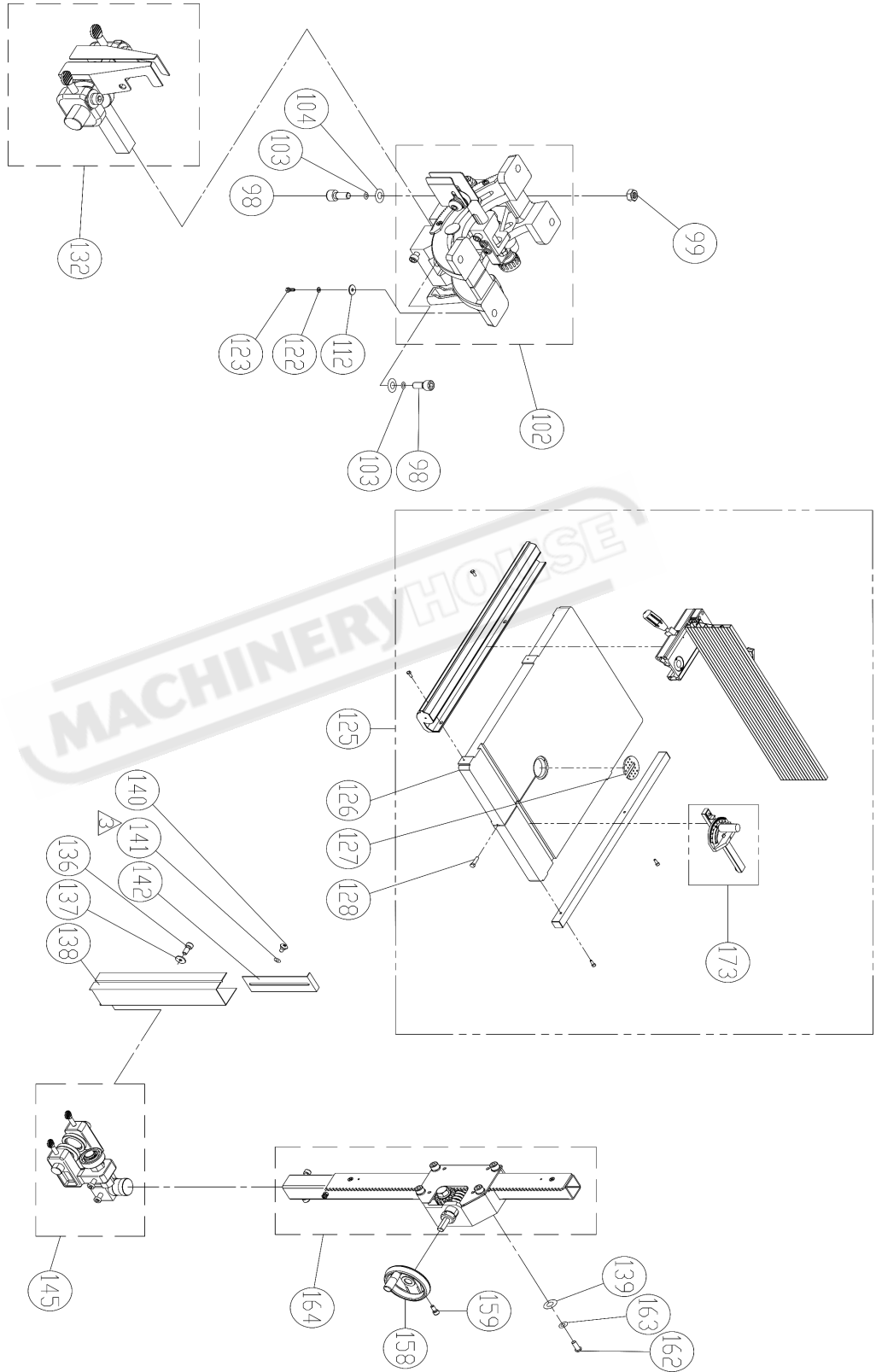

BP-480A MACHINE SPARE PARTS LIST

No.	Part No.	Description	Specification	Qty
1	WF040808	FLAT WASHER	M4x8	6
2	NH040700	NUT	M4	4
3	SP040200	PAN HEAD SCREW	M4x8	2
4	995101	RING	M10	1
5	13612	MACHINE BODY		1
6	NF050800	NUT	M5	2
7	IC135042	SWITCH CORD		1
8	WF061310	FLAT WASHER	M6x13	2
9	IC135001	POWER CORD	3P+G	1
10	NH061000	NUT	M6	1
11	135040	POINTER		1
12	135073	STEP SCREW		1
13	135012	UPPER SHAFT		1
14	PS053600	SPRING PIN	Ø5x36	1
15	135017	UPPER WHEEL SHAFT HINGE		1
16	135066	UPPER WHEEL SHAFT		1
17	135039	BUSHING		2
18	BB620403	BALL BEARING	6204LLU	4
19	136002	UPPER WHEEL	Ø 19"	1
20	RR470000	RETAINING RING	R47	4
21	WF083030	FLAT WASHER	M8x30	2
22	SR089400	HEX SOCKET BOLT	M8x16	2
23	136010	SAW BLADE	6TPI 3632.2x3/4"0.5mm	1
24	WS080000	SPRING WASHER	M8	2
25	SR060600	HEX SOCKET BOLT	M6x30	6
26	136065	TIRE		2
27	136003	LOWER WHEEL	Ø 19"	1
28	135007	IDLE PULLEY		1
29	NH633801	NUT	1"-14 UNF	1
30	WS630000	SPRING WASHER	1"	1
31				
32	135032	SPRING		1
33	PS031600	SPRING PIN	Ø3x16	1
34	135042	LOCATE BLOCK		1
35	994301	BEARING	51201	1
36				
37	135002	HANDLE WHEEL		1
38	136007	ADJUSTING BOLT		1
39	SF050200	PAN HEAD BOLT W/FLANGE	M5x10	8

BP-480A MACHINE SPARE PARTS LIST

No.	Part No.	Description	Specification	Qty
40				
41	135067	BUSHING		1
42				
43				
44	SR089400	HEX SOCKET BOLT	M8x16	2
45	WF083030	FLAT WASHER	M8x30	2
46	135016	UPPER WHEEL SLIDING BRACKET		1
47	SR061000	HEX SOCKET BOLT	M6x25	1
48	BR000041	RIVET	Ø3.2x10	8
49	SR060200	HEX SOCKET BOLT	M6x10	1
50	135004	LIMPID PIECE		2
51	SF040700	PAN HEAD BOLT W/FLANGE	M4x35	2
52	136457	DOOR LATCH SWITCH(ASM)	AZD-S11	1
53	WS050000	SPRING WASHER	M5	2
54	136475	FLAT WASHER	M5x12	2
55	136166	UPPER WHEEL COVER		1
56	SH060500	HEX HEAD BOLT	M6x25	2
57	WF061310	FLAT WASHER	M6x13	2
58	135051	BRUSH		2
59	WF061310	HEX SOCKET BOLT	M6x25	1
60	135051	KNOB		2
61	NL061000	NYLON NUT	M6	6
62	709416	STRAIN RELIEF	M16	2
63	135011	HEIGHT POINTER		1
64	NH081300	NUT	M8	1
65	SH081800	HEX HEAD BOLT	M8x90	1
66	135022	KNOB SCREW	M10x20	1
67	135020	KNOB SCREW	M10x53	1
68	135028	LOCATE HANDLE	M10	1
69	135030	CAM		1
70	135038	LOCATE BLOCK		1
71	620021	KNOB		1
72	620020	LEVER ROD		1
73	NH121900	NUT	M12	1
74	135036	SHAFT		1
75	SJ080400	HEX SOCKET HEAD SCREW	M8x20	4
76	WS080000	SPRING WASHER	M8	4
77	WS080000	SPRING WASHER	M8	1
78	135013	COVER		1
79	SS080400	SET BOLT	M8x20	4
80	NH081300	NUT	M8	4

BP-480A MACHINE SPARE PARTS LIST

No.	Part No.	Description	Specification	Qty
81	135005	LOWER WHEEL SHAFT		1
82	MH135004	MOTOR	1 HP	1
83	SR100500	HEX SOCKET BOLT	M10x25	2
84	WS100000	SPRING WASHER	M10	2
85	135064	MOTOR BRACKET		1
86	SJ080400	HEX SOCKET HEAD SCREW	M8x20	4
87	135081	PLATE		1
88	SF050200	PAN HEAD BOLT W/FLANGE	M5x10	2
89	135065	LOCATE BLOCK		1
90	KS050535	KEY	5x5x35	1
91	SH080402	HEX HEAD BOLT	M8x20(L.H)	1
92	135008	MOTOR PULLEY		1
93	LA420000	V-BELT	A42	1
94	SR060200	HEX SOCKET BOLT	M6x10	1
95	136167	LOWER WHEEL COVER		1
96	SJ059400	HEX SOCKET BOTTOM HEAD SCREW	M5x16	2
97	WF083030	FLAT WASHER	M8x30	1
98	SR100700	HEX SOCKET BOLT	M10x35	2
99	NH101700	NUT	M10	1
100				
101				
102	AB135250	TRUNNION SUPPORT BRACKET(ASM)		1
103	WS100000	SPRING WASHER	M10	2
104	WF102325	FLAT WASHER	M10x23	2
105				
106				
107				
108				
109				
110				
111				
112	WF081820	FLAT WASHER	M8x18	4
122	WS080000	SPRING WASHER	M8	4
123	SH089400	HEX HEAD BOLT	M8X16	4
124				
125	QF198022-B	19" FENCE SET		1
126	135127	TABLE		1
127	135010	TABLE INSERT		1
128	100038	TABLE PIN		1
132	AB135059	LOWER BLADE GUIDE SUPPORT(ASM)		1
135				
136	SR050200	HEX SOCKET BOLT	M5X10	2
137	WF051210	FLAT WASHER	M5X12	2
138	135034	PROTECT COVER(ASM)		1
140	135073	STEP SCREW		1

BP-480A MACHINE SPARE PARTS LIST

No.	Part No.	Description	Specification	Qty
141	135054	FIBER WASHER	4-13x6x1.2	1
142	135037	SLIDING PLATE		1
143				
144				
145	AB135055	UPPER BLADE GUIDE SUPPORT(ASM)		1
146				
152	SR060400	HEX SOCKET BOLT	M6x20	2
153				
154				
155				
156				
157				
158	135006	HANDLE WHEEL		1
159	SR060400	HEX SOCKET BOLT	M6x20	1
160				
161				
162	SJ080400	HEX SOCKET BOTOM HEAD SCREW	M8x20	4
163	WS080000	SPRING WASHER	M8	4
164	AB135050	GUIDE BRACKET(ASM)		1
173	AB198101	MITER GAUGE ASS'Y		
174				
175	SS060400	SET SCREW	M6x20	1
176	SF050200	PAN HEAD BOLT W/FLANGE	M5x10	2
177				
178				
179	612112	BUSHING		1
180	WF081820	FLAT WASHER	M8x18	4
181	136019	WIRE CONECTOR	224-201	5
182	135127	TAPPING SCREW	M3.5x12(AB)	2
183	136017B	BRAKING SWITCH	K400	1
184	135099	SWITCH PLATE		1
185				
186				
187				
188				

NOTE: SOME INDIVIDUAL PARTS MAY ONLY BE AVAILABLE AS AN ASSEMBLY

BP-480A FENCE SPARE PARTS DIAGRAM

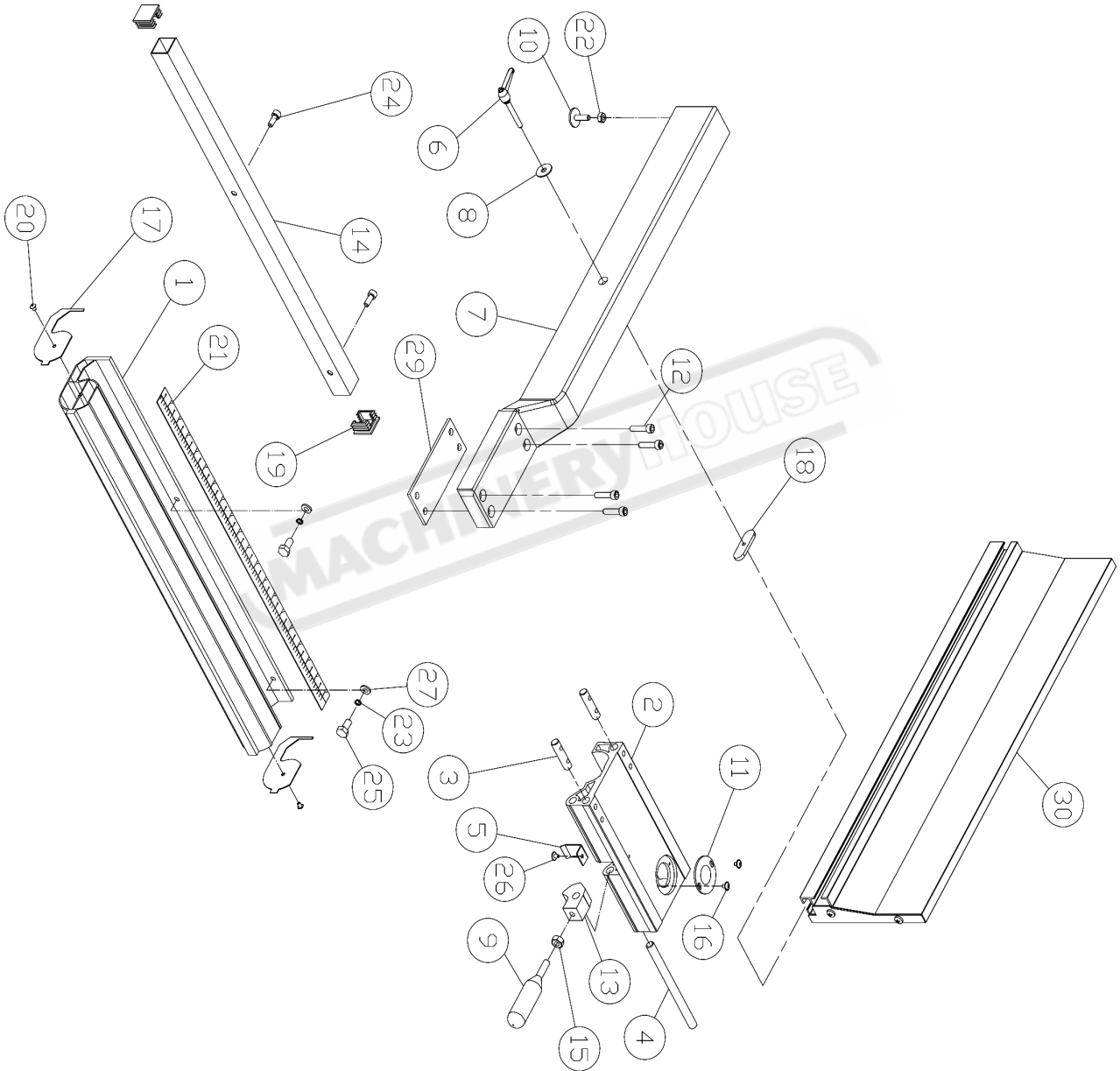

BP-480A FENCE SPARE PARTS LIST

No.	Part No.	Description	Specification	Qty
30	AC198083	FENCE (AL)	640	
29	198008	BRACKET	T=3	
27	WF061310	FLAT WASHER	M6x13	1
26	SF049200	PAN HEAD BOLT W/FLANGE	M4x8	2
25	SH060400	HEX HEAD BOLT	M6x20	1
24	SR069400	HEX SOCKET BOLT	M6x16	2
23	3S060000	SPRING WASHER	M6	2
22	NH061000	NUT	M6	2
21	LM001035	SCALE		
20	ST039300	TAPPING SCREW	M3.5x12	
19	198016	PLUGGED		2
18	200527	MOVING PLATE		2
17	198014	GUARD PIECE		
16	SF049100	PAN HEAD BOLT W/FLANGE	M4x6	2
15	NH081300	NUT	M8	2
14	198023	SQUARE TUBE	710	
13	198004	FIXED LUMP		
12	SR060500	HEX SOCKET BOLT	M6x25	
11	198007	CONVEX		4
10	198012	ADJUST SCREW		
09	198013	HANDLE		
08	WF082320	FLAT WASHER	M8x Ø 23	
07	198078	SUPPORT TUBE	640	
06	198074	LOCK KNOB	M8x44	
05	198006	SPRING WASHER		
04	198005	SHAFT		
03	198003	FIXED SHAFT		
02	198002	ADJUST BASE		2
01	198022	FIXED BASE	710	1

NOTE: SOME INDIVIDUAL PARTS MAY ONLY BE AVAILABLE AS AN ASSEMBLY

BP-480A UPPER GUIDE SPARE PARTS DIAGRAM

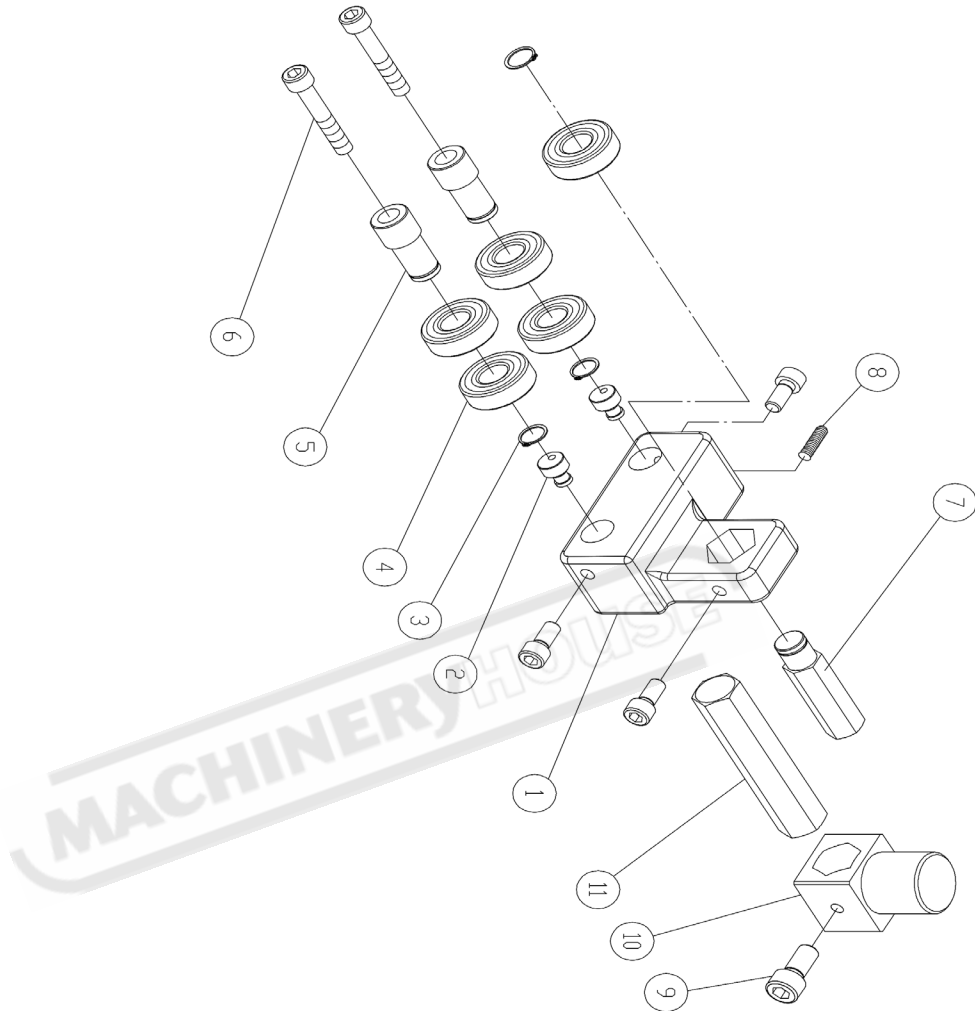

BP-480A UPPER GUIDE SPARE PARTS LIST

No.	Part No.	Description	Specification	Qty
1	135091	UPPER BLADE GUIDE SUPPORT		1
2	13590	BIAS SHAFT		2
3	RS150000	RING	S15	3
4	BB620202A	BALL BEARING	6202ZZ	5
5	136445	HANDLE BUSHING		2
6	SR060703	HEX SOCKET BOLT	M6x35	2
7	135060	UPPER SPACING SLEEVE		
8	SS060200	SET BOLT	M6x10	
9	SR069400	HEX SOCKET BOLT	M6x16	4
10	135057	UPPER GUIDE SUUPORT BLOCK		
11	135053	ADJUST BAR		

NOTE: SOME INDIVIDUAL PARTS MAY ONLY BE AVAILABLE AS AN ASSEMBLY

BP-480A LOWER GUIDE SPARE PARTS DIAGRAM

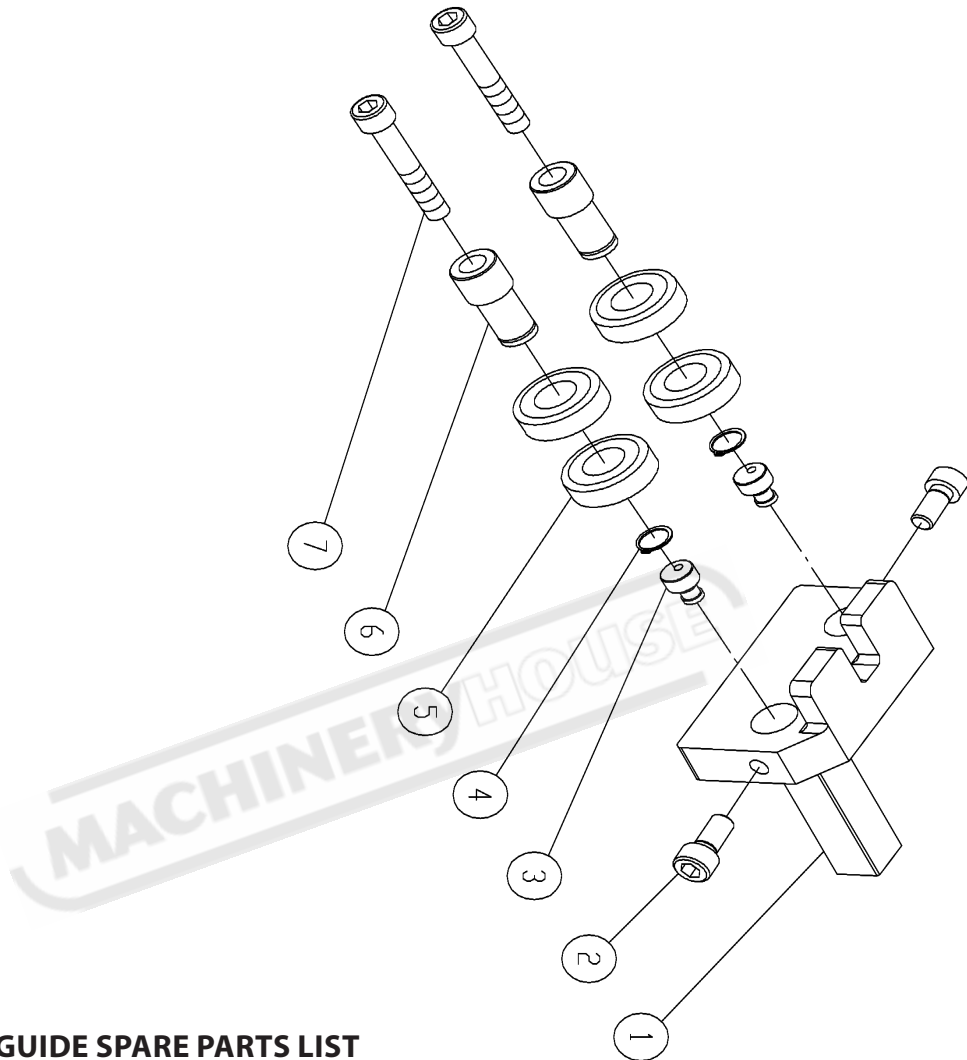

BP-480A LOWER GUIDE SPARE PARTS LIST

No.	Part No.	Description	Specification	Qty
1	135091	UPPER BLADE GUIDE SUPPORT		1
2	135090	BIAS SHAFT		2
3	RS150000	RING	S15	3
4	BB620202A	BALL BEARING	6202ZZ	5
5	136445	HANDLE BUSHING		2
6	SR060703	HEX SOCKET BOLT	M6x35	2
7	135060	UPPER SPACING SLEEVE		
8	SS060200	SET BOLT	M6x10	
9	SR069400	HEX SOCKET BOLT	M6x16	4
10	135057	UPPER GUIDE SUUPPORT BLOCK		
11	135053	ADJUST BAR		

NOTE: SOME INDIVIDUAL PARTS MAY ONLY BE AVAILABLE AS AN ASSEMBLY

ELECTRICAL DRAWING

*electrical power supply:
1~ 230V~240V 50Hz

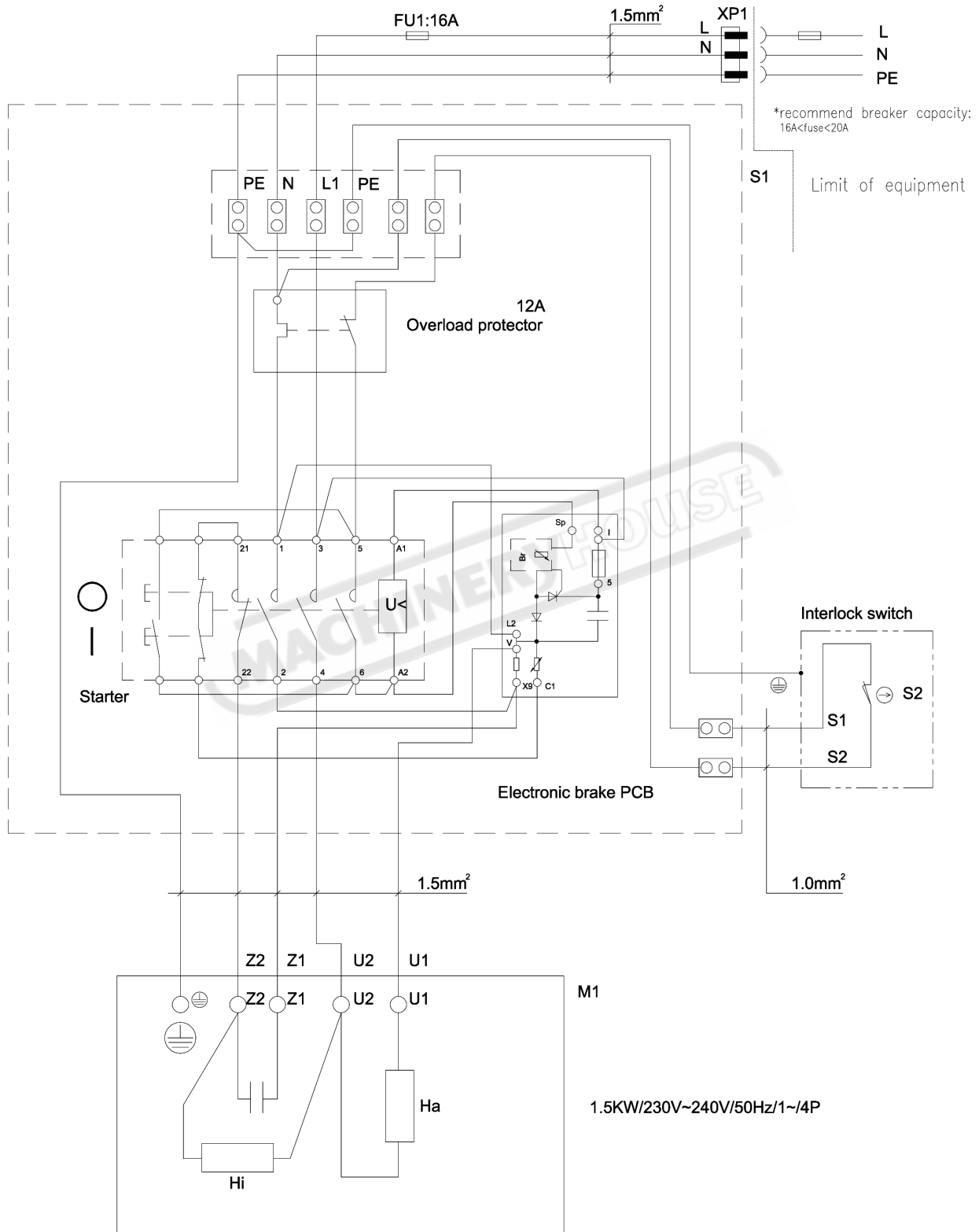

MOTOR

WARNING

General Machinery Safety Instructions

Machinery House
requires you to read this entire Manual before using this machine.

- 1. Read the entire Manual before starting machinery.** Machinery may cause serious injury if not correctly used.
- 2. Always use correct hearing protection when operating machinery.** Machinery noise may cause permanent hearing damage.
- 3. Machinery must never be used when tired, or under the influence of drugs or alcohol.** When running machinery you must be alert at all times.
- 4. Wear correct Clothing.** At all times remove all loose clothing, necklaces, rings, jewelry, etc. Long hair must be contained in a hair net. Non-slip protective footwear must be worn.
- 5. Always wear correct respirators around fumes or dust when operating machinery.** Machinery fumes & dust can cause serious respiratory illness. Dust extractors must be used where applicable.
- 6. Always wear correct safety glasses.** When machining you must use the correct eye protection to prevent injuring your eyes.
- 7. Keep work clean and make sure you have good lighting.** Cluttered and dark shadows may cause accidents.
- 8. Personnel must be properly trained or well supervised when operating machinery.** Make sure you have clear and safe understanding of the machine you are operating.
- 9. Keep children and visitors away.** Make sure children and visitors are at a safe distance for you work area.
- 10. Keep your workshop childproof.** Use padlocks, Turn off master power switches and remove start switch keys.
- 11. Never leave machine unattended.** Turn power off and wait till machine has come to a complete stop before leaving the machine unattended.
- 12. Make a safe working environment.** Do not use machine in a damp, wet area, or where flammable or noxious fumes may exist.
- 13. Disconnect main power before service machine.** Make sure power switch is in the off position before re-connecting.
- 14. Use correct amperage extension cords.** Undersized extension cords overheat and lose power. Replace extension cords if they become damaged.
- 15. Keep machine well maintained.** Keep blades sharp and clean for best and safest performance. Follow instructions when lubricating and changing accessories.
- 16. Keep machine well guarded.** Make sure guards on machine are in place and are all working correctly.
- 17. Do not overreach.** Keep proper footing and balance at all times.
- 18. Secure workpiece.** Use clamps or a vice to hold the workpiece where practical. Keeping the workpiece secure will free up your hand to operate the machine and will protect hand from injury.
- 19. Check machine over before operating.** Check machine for damaged parts, loose bolts, Keys and wrenches left on machine and any other conditions that may effect the machines operation. Repair and replace damaged parts.
- 20. Use recommended accessories.** Refer to instruction manual or ask correct service officer when using accessories. The use of improper accessories may cause the risk of injury.
- 21. Do not force machinery.** Work at the speed and capacity at which the machine or accessory was designed.
- 22. Use correct lifting practice.** Always use the correct lifting methods when using machinery. Incorrect lifting methods can cause serious injury.
- 23. Lock mobile bases.** Make sure any mobile bases are locked before using machine.
- 24. Allergic reactions.** Certain metal shavings and cutting fluids may cause an allergic reaction in people and animals, especially when cutting as the fumes can be inhaled. Make sure you know what type of metal and cutting fluid you will be exposed to and how to avoid contamination.
- 25. Call for help.** If at any time you experience difficulties, stop the machine and call you nearest branch service department for help.

WARNING

Wood Bandsaw Safety Instructions

Machinery House
requires you to read this entire Manual before using this machine.

- 1. Maintenance.** Make sure the bandsaw is turned off and disconnect from the main power supply and make sure all moving parts have come to a complete stop before any inspection, adjustment or maintenance is carried out.
- 2. Bandsaw Condition.** Bandsaw must be maintained for a proper working condition. Never operate a bandsaw that has damaged or worn parts. Scheduled routine maintenance should be performed on a scheduled basis.
- 3. Blade Condition.** Never operate a bandsaw with a dull, cracked or badly worn blade. Before using a bandsaw inspect blades for missing teeth and cracks. Replace if required.
- 4. Replacing Blade.** Make sure teeth are face forward to the workpiece and blade is properly tensioned. Wear gloves to protect hands and wear safety glasses to protect your eyes.
- 5. Use Correct Blade.** Use the correct blade for the material being cut and the type of cut you are performing.
- 6. Hand Hazard.** Keep hands and fingers clear from the line of cut of the blade. Serious injury can occur.
- 7. Leaving a bandsaw Unattended.** Always turn the bandsaw off and make sure all moving parts have come to a complete stop before leaving the bandsaw. Do not leave bandsaw running unattended for any reason.
- 8. Avoiding Entanglement.** Blade guard must be used at all times. Remove loose clothing, belts, or jewelry items. Never wear gloves while machine is in operation. Tie up long hair and use the correct hair nets to avoid any entanglement with the bandsaw moving parts.
- 9. Understand the machines controls.** Make sure you understand the use and operation of all controls.
- 10. Power outage.** In the event of a power failure during use of the bandsaw, turn off all switches to avoid possible sudden start up once power is restored.
- 11. Work area hazards.** Keep the area around the bandsaw clean from oil, tools, chips. Pay attention to other persons in the area and know what is going on around the area to ensure unintended accidents.
- 12. Workpiece Handling.** Never hold small workpieces with your fingers during a cut. Always support/feed the workpiece with push stick, table support, vice, or some sort of clamping fixture.
- 13. Hearing protection and hazards.** Always wear hearing protection as noise generated from bandsaw blade and workpiece vibration, material handling can cause permanent hearing loss over time.
- 14. Cutting techniques.** Plan your cuts so you always cut out of the wood. Do not back the workpiece away from the blade while the saw is running. If you need to back the workpiece out, turn off the bandsaw and wait till the blade has come to a complete stop, and do not twist or put excessive stress on the blade while backing work out.
- 15. Feeding material.** Always feed material evenly and smoothly. Do not force or twist blade while cutting, especially while cutting small radii material.
- 16. Job Material.** This machine is designed to cut wood only. It is not designed to cut metal or use cutting fluid. Always inspect your material before cutting. If you have any doubt about stability or structural integrity of your stock do not cut.
- 17. Starting position/speed.** Never turn the bandsaw on when the blade is resting on the workpiece. Allow blade to reach full speed before cutting.
- 18. Guards.** Do not operate bandsaw without the blade guard in place or with the doors open. Ensure all guards removed to do maintenance or change blades on the machine are refitted correctly in place before the machine is used again.
- 19. Stopping the Blade.** Do not stop or slow the blade with your hand or workpiece. Allow the blade to stop on its own, unless the machine is equipped with a brake.
- 20. Call for help.** If at any time you experience difficulties, stop the machine and call your nearest branch service department for help.

PLANT SAFETY PROGRAM

NEW MACHINERY HAZARD IDENTIFICATION, ASSESSMENT & CONTROL

Wood Bandsaw

Developed in Co-operation Between A.W.I.S.A and Australia Chamber of Manufactures
This program is based upon the Safe Work Australia, Code of Practice - Managing Risks of Plant in the Workplace (WHSA 2011 No10)



Item No.	Hazard Identification	Hazard Assessment	Risk Control Strategies <small>(Recommended for Purchase / Buyer / User)</small>
A	ENTANGLEMENT	HIGH	Eliminate, avoid loose clothing / Long hair etc.
B	CRUSHING	LOW	Ensure bandsaw is on level ground to and safe place to prevent it falling.
C	CUTTING, STABBING, PUNCTURING	MEDIUM	Blade guards should always be in the closed position before starting machine. Top blade guide system should be adjusted to suit material thickness. Isolate main power switch before changing blade, cleaning or adjusting. Use a push stick to remove off-cuts. Hands must always be kept well away from blade at all times. Check blade tracking before starting.
D	SHEARING	MEDIUM	Make sure all guards are secured shut when machine is on.
F	STRIKING	LOW	Support long heavy work pieces. Remove all loose objects around moving parts. Wear safety glasses
H	ELECTRICAL	MEDIUM	Should blade break turn off machine immediately and use foot brake to stop if supplied. All electrical enclosures should only be opened with a tool that is not to be kept with the machine.
O	OTHER HAZARDS, NOISE, DUST.	LOW	Wear hearing protection as required. Must be connected to dust extraction.
Plant Safety Program to be read in conjunction with manufactures instructions			



www.machineryhouse.com.au



www.machineryhouse.co.nz

Authorised and signed by:
Safety officer: 
Manager: 

Revised Date: 12th March 2012